

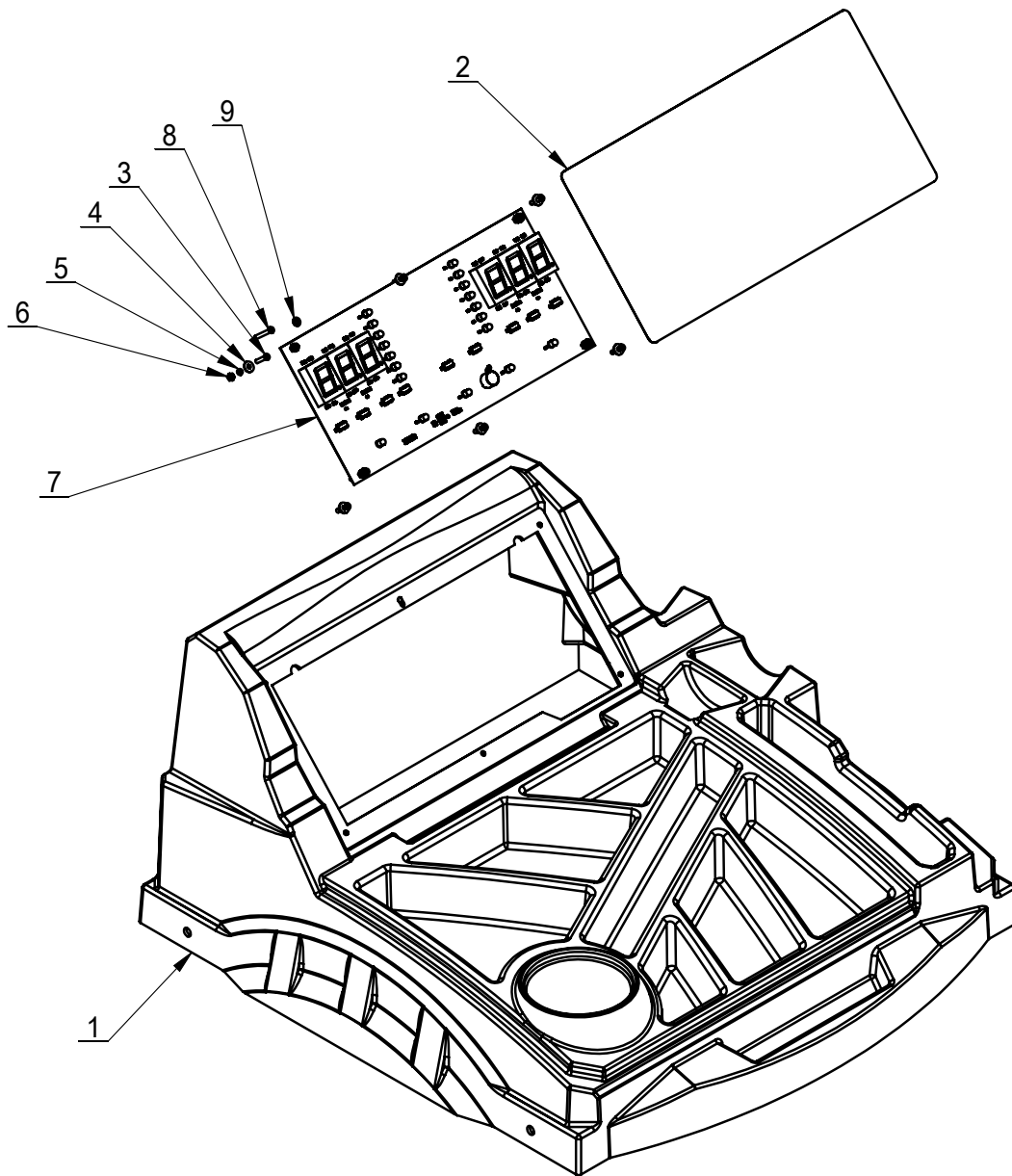

ITEM	PART.No	DESCRIPTION.	QT.Y
1	B-12-3100000	CLASSIS-WELD COMP	1
2	TB-F-0500000	HOOD	1
3	TB-P-0600000L	BALANCER SPINDLE	1
4	TB-P-0110000	PRESS SENSOR ASSEMBLY	1
5	B-01-1000100	MOTOR HOLDER	1
6	GB5781-M8×20	HEXANGULAR BOLT	4
7	GB93-8	STANDARD SPRING WASHER	4
8	GB95-8	FLAT WASHER	4
9	TB-E-1000100	POWER CABLE ASSEMBLY	1
10	GB818-M5×8-H	CROSS PANHEAD SCREW	2
11	GB70.1-M10×25	INNER HEXA CYLINDRICAL SCREW	4
12	GB93-10	STANDARD SPRING WASHER	4
13	GB95-10	FLAT WASHER	4
14	B-01-1008001	SWITCH CONNECTION LINE	1
15	B-01-1008002	Power board connections	1
16	B-01-1008003	DISPLAY PANEL CABLE	1
17	B-01-1008004	DISPLAY PANEL CABLE	1
18	B-01-1008005	EARTH WIRE	1
19	B-01-1000006	WEDGE BELT(940mm)	1
20	GB70.1-M6×16	INNER HEXA CYLINDRICAL SCREW	4
21	GB93-6	STANDARD SPRING WASHER	5
22	GB95-6	FLAT WASHER	5
23	B-53-1000007	NUT M4	4
24	GB818-M6×12-H	CROSS PANHEAD SCREW	1
25	B-53-1000006	SCREW M4	4
26	C-71-1000019	RUBBER GROMMET	1
27	B-53-1000008	FIX PLATE	4
28	B-53-1000009	NYLON BELT	5
29	B-01-1000010	COMPUTER BOARD	1
30	TB-E-1210000	POWER SUPPLY ASSEM	1
31	TB-E-9001220	MOTOR ASSEMBLY PART	1
32	TB-E-1001101	POWER SWITCH	1
33	B-01-1008006	OPTICBACKPANEL CABLE	1
34	B-01-1000008	ASSESS HOLES COVER	1
35	TB-S-0100009	CONE HANG HANDLE	2
36	TB-L-0101000H	SCALE ASSEMBLY	1
37	B-12-3200000	WEIGHT TRAY ASSEMBLY	1
38	GB819.1-M5×12-H	CROSS COUNTERSUNK SCREW STEEL 4.8 GRADE	2
39	GB95-5	FLAT WASHER	2
40	GB93-5	STANDARD SPRING WASHER	2
41	GB6170-M5	HEXANGULAR NUT 1-TYPE	2

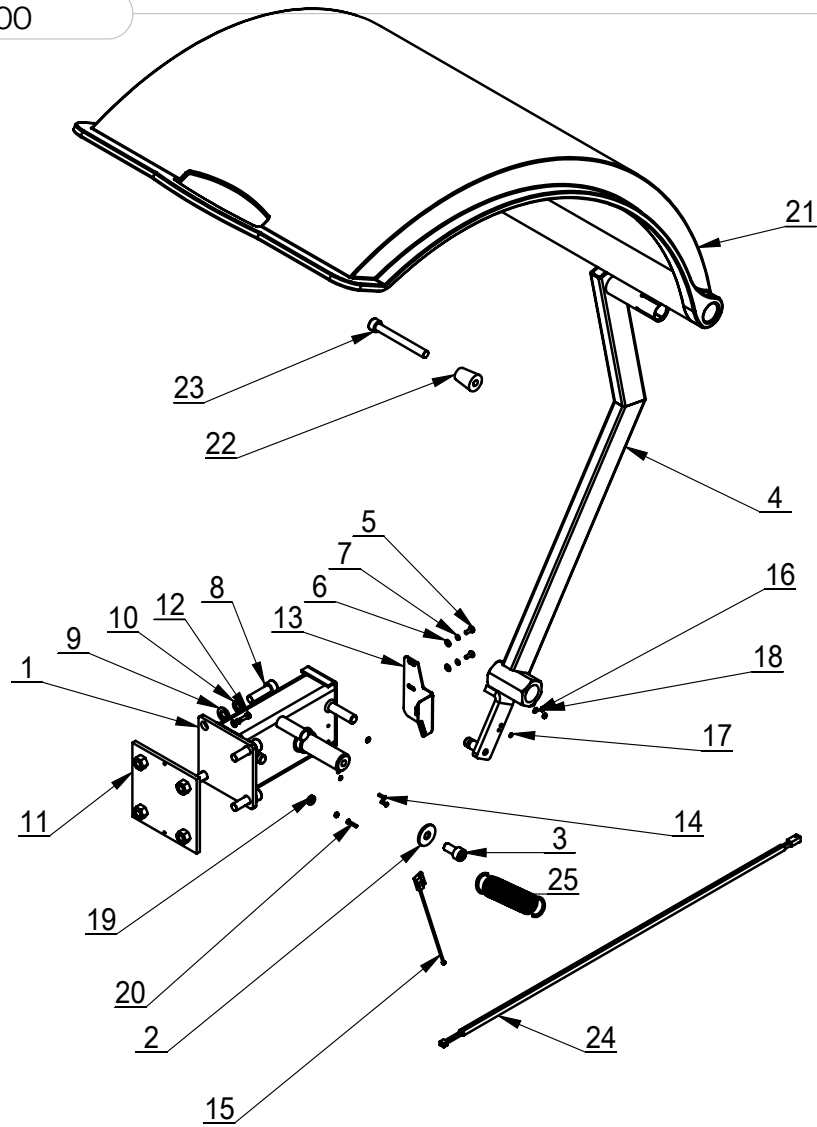

ITEM	PART.No	DESCRIPTION.	QT.Y
1	B-12-3200001	WEIGHT TRAY	1
2	B-12-3200002	PANEL	1
3	GB819.1-M3×16-H	CROSS COUNTERSUNK SCREW STEEL 4.8 GRADE	6
4	GB96.2-3	LARGE WASHER C GRADE	6
5	GB93-3	STANDARD SPRING WASHER	14
6	GB6170-M3	HEXANGULAR NUT 1-TYPE	18
7	B-10-1200102	DISPLAY BOARD	1
8	GB819.1-M3×25-H	CROSS COUNTERSUNK SCREW STEEL 4.8 GRADE	4
9	GB95-3	FLAT WASHER	8



ITEM	PART.No	DESCRIPTION.	QT.Y
1	TB-F-0110000	PROTECTIVE HOOD SUPPORT	1
2	GB96.1-10	LARGE WASHER A GRADE	1
3	GB70.1-M10×20	INNER HEXA CYLINDRICAL SCREW	1
4	TB-F-0500100	PROTECTIVE HOOD SUPPORTT	1
5	GB818-M4×10-H	CROSS PANHEAD SCREW	2
6	GB95-4	FLAT WASHER	4
7	GB93-4	STANDARD SPRING WASHER	4
8	GB70.1-M10×35	INNER HEXA CYLINDRICAL SCREW	4
9	GB95-10	FLAT WASHER	4
10	GB93-10	STANDARD SPRING WASHER	4
11	TB-F-0130000	CONNECTING PLATE	1
12	GB70.1-M4×12	INNER HEXA CYLINDRICAL SCREW	2
13	TB-F-0100017	PROTECTIVE PLATE	1
14	GB819.1-M3×10-H	CROSS COUNTERSUNK SCREW STEEL 4.8 GRADE	2
15	B-53-1000010	MAGNETIC SWITCH	1
16	GB95-3	FLAT WASHER	3
17	GB93-3	STANDARD SPRING WASHER	3
18	GB6170-M3	HEXANGULAR NUT 1-TYPE	3
19	TB-F-0100016	MAGNET	1
20	GB819.1-M3×16-H	CROSS COUNTERSUNK SCREW STEEL 4.8 GRADE	1
21	TB-F-0500001	HOOD	1
22	TB-F-0500104	LOCKING	1
23	GB70.1-M10×90	INNER HEXA CYLINDRICAL SCREW	1
24	B-53-1000016	power line	1
25	TB-F-0500002	SUPPORT PIPE EXTENSION SPRING	1

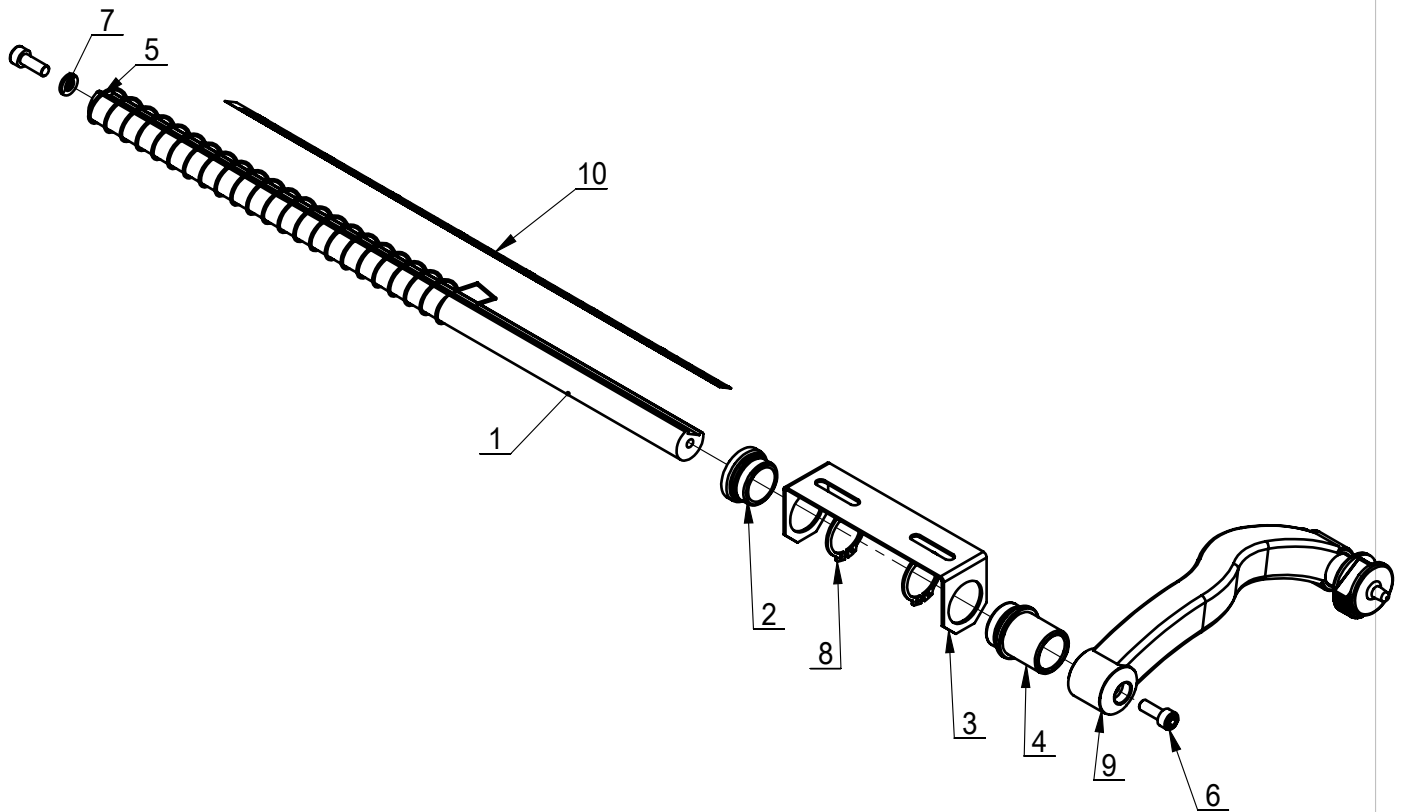

ITEM	PART.No	DESCRIPTION.	QT.Y
1	TB-L-0101001H	DISTANCE GAUGE ROD	1
2	TB-L-0101002	HARNESS	1
3	TB-L-0101003H	SCALE HOLDER	1
4	TB-L-0101005	HARNESS	1
5	TB-L-0101007	SPRING	1
6	GB70.1-M6×16	INNER HEXA CYLINDRICAL SCREW	2
7	GB95-6	FLAT WASHER	1
8	GB894.1-25	SHAFT ELATIC BIG RETAINING RING A-TYPE	2
9	TB-L-0802000	DISTANCE GAUGE HANDLE ASSEMBL	1
10	B-73-1300010	SCALE	1

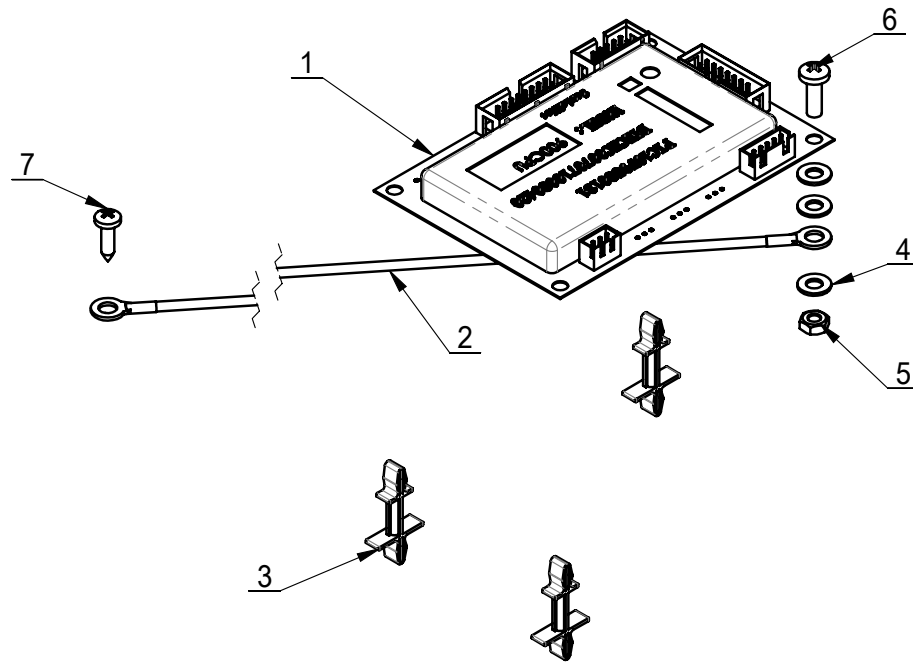

ITEM	PART.No	DESCRIPTION.	QT.Y
1	B-12-1000001	CPU-900	1
2	B-56-1500105	CPU LINE	1
3	TB-E-1211002	PLASTIC CLIPPER	3
4	GB95-4	FLAT WASHER	3
5	GB6170-M4	HEXANGULAR NUT 1-TYPE	1
6	GB818-M4×12-H	CROSS PANHEAD SCREW	1
7	GB845-ST3.5×13 H C	CROSS PANHEAD TAPPING SCREW	1

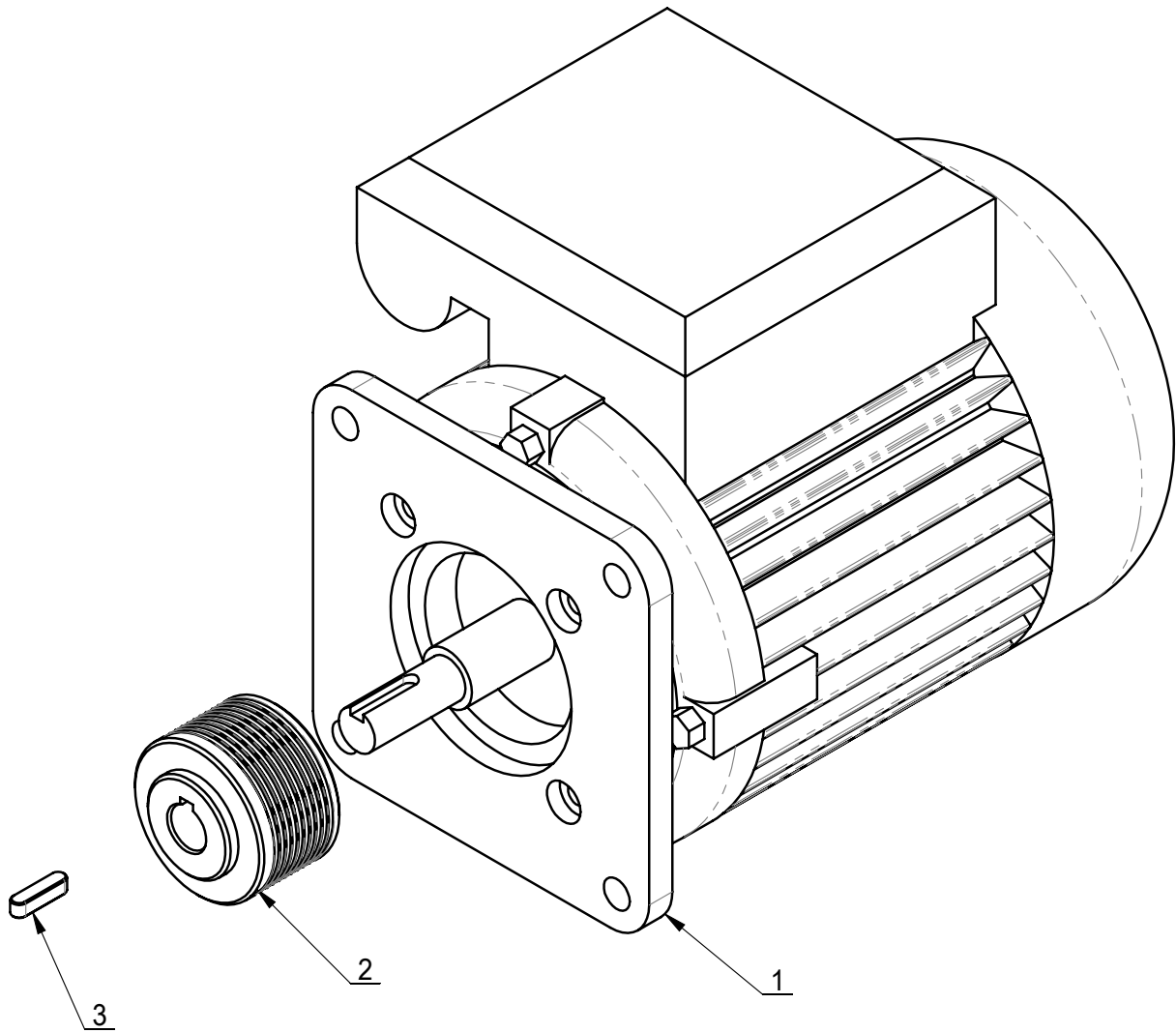

ITEM	PART.No	DESCRIPTION.	QT.Y
1	TB-E-9000220	MOTOR	1
2	B-53-1000003	MOTOR BELT PULLEY	1
3	GB1096-5×5×20	COMMON FLAT KEY	1

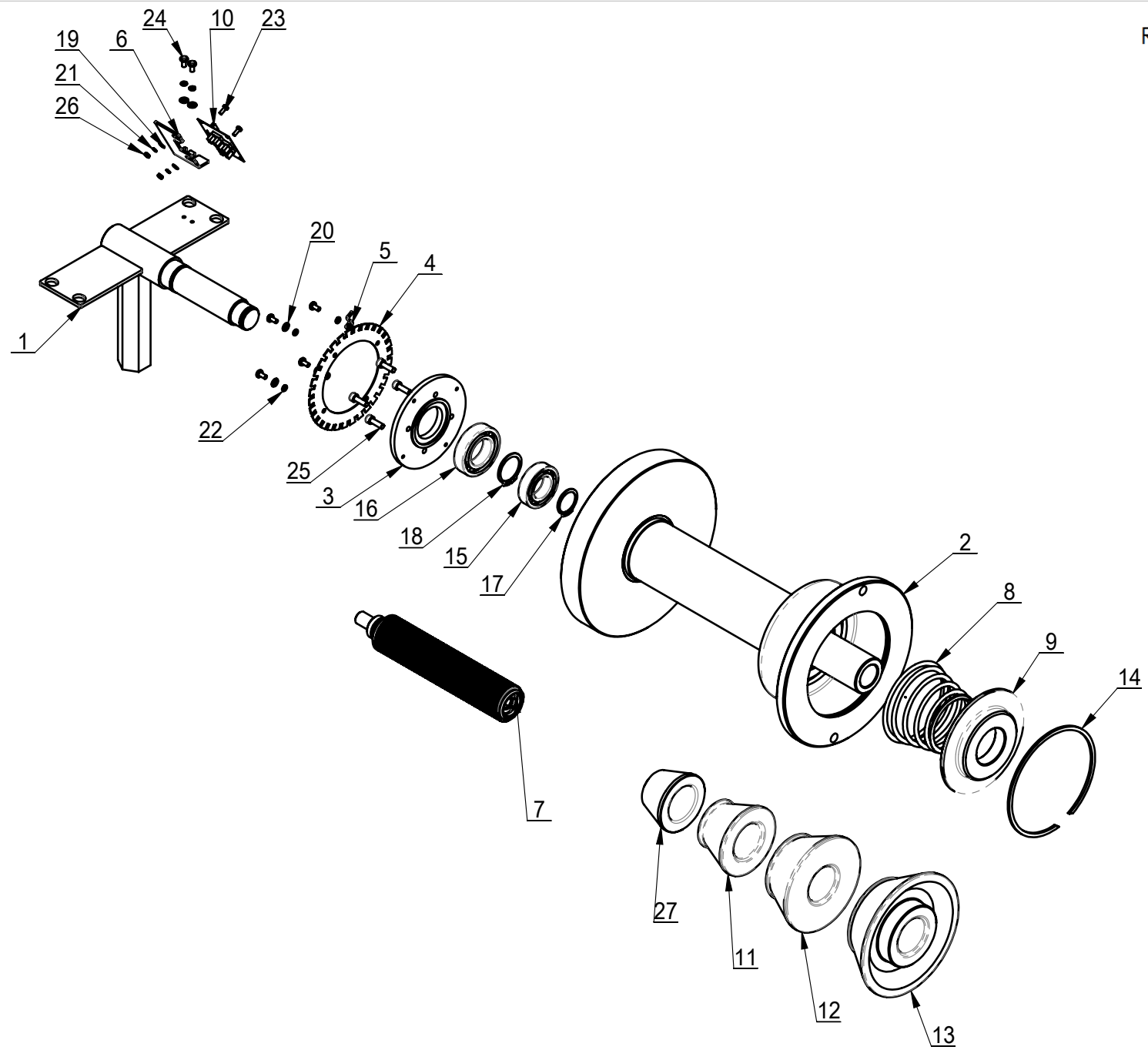

ITEM	PART.No	DESCRIPTION.	QT.Y
1	TB-P-0101000	FIXING SHAFT WELDING	1
2	TB-P-0602000L	MAIN SHAFT WELDING	1
3	TB-P-0100001	BEARING PRESS HOUSING	1
4	TB-P-0100002	PHOTOELECTRIC SET	1
5	TB-P-0100003	PHOTOELECTRIC TOOTH	1
6	TB-P-0100004	ENCODER CELL PLATE	1
7	B-73-1215000	BALANCER SPINDLE	1
8	TB-P-0100009	SPRING	1
9	TB-P-0300008	SPRING PRESS COVER	1
10	TB-P-0100011	ANGLE SENSOR	1
11	TB-P-0300032	40CONE 54-78	1
12	TB-P-0300033	40CONE 74-108	1
13	TB-P-0300034	40CONE 89-140	1
14	TB-P-0300009	ROLLAR	1
15	GB276-6005	DEEP GROOVE BALL BEARINGS	1
16	GB276-6006	DEEP GROOVE BALL BEARINGS	1
17	GB894.2-25	SHAFT ELATIC RETAINING RING B-TYPE	1
18	GB894.2-30	SHAFT ELATIC RETAINING RING B-TYPE	1
19	GB95-3	FLAT WASHER	2
20	GB95-4	FLAT WASHER	5
21	GB93-3	STANDARD SPRING WASHER	2
22	GB93-4	STANDARD SPRING WASHER	6
23	GB818-M3×8-H	CROSS PANHEAD SCREW	2
24	GB818-M4×8-H	CROSS PANHEAD SCREW	6
25	GB70.1-M5×16	INNER HEXA CYLINDRICAL SCREW	4
26	GB6170-M3	HEXANGULAR NUT 1-TYPE	2
27	TB-P-0300031	40CONE 42-65	1

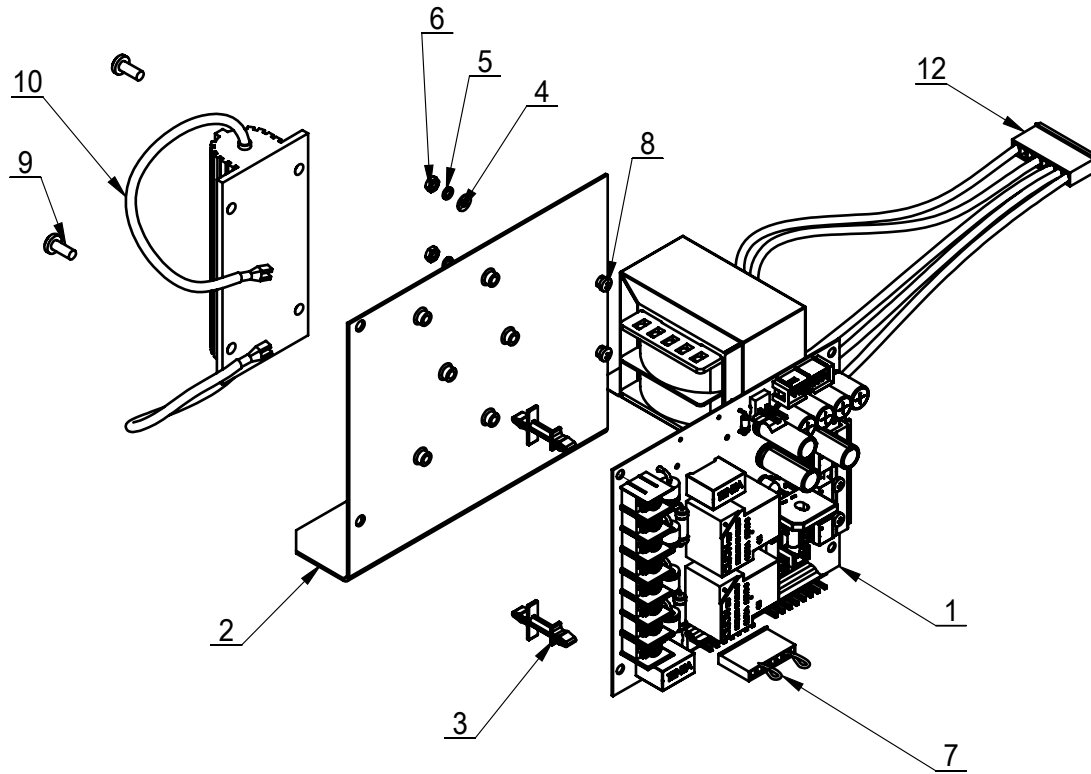

ITEM	PART.No	DESCRIPTION.	QT.Y
1	TB-E-1211100	POWER BOARD	1
2	TB-E-1211001	SUPPORT PLATE	1
3	TB-E-1211002	PLASTIC CLIPPER	2
4	GB95-3	FLAT WASHER	2
5	GB93-3	STANDARD SPRING WASHER	2
6	GB6170-M3	HEXANGULAR NUT 1-TYPE	2
7	TB-E-1006004	JUMPER No4	1
8	GB818-M3×8-H	CROSS PANHEAD SCREW	2
9	GB818-M4×10-H	CROSS PANHEAD SCREW	2
10	TB-E-1211212	RESISTANCE	1
11	GB845-ST3.5×13 H C	CROSS PANHEAD TAPPING SCREW	4
12	TB-E-1258220	EARTH WIRE	1

REVISION 16A-01

TB-P-0110000

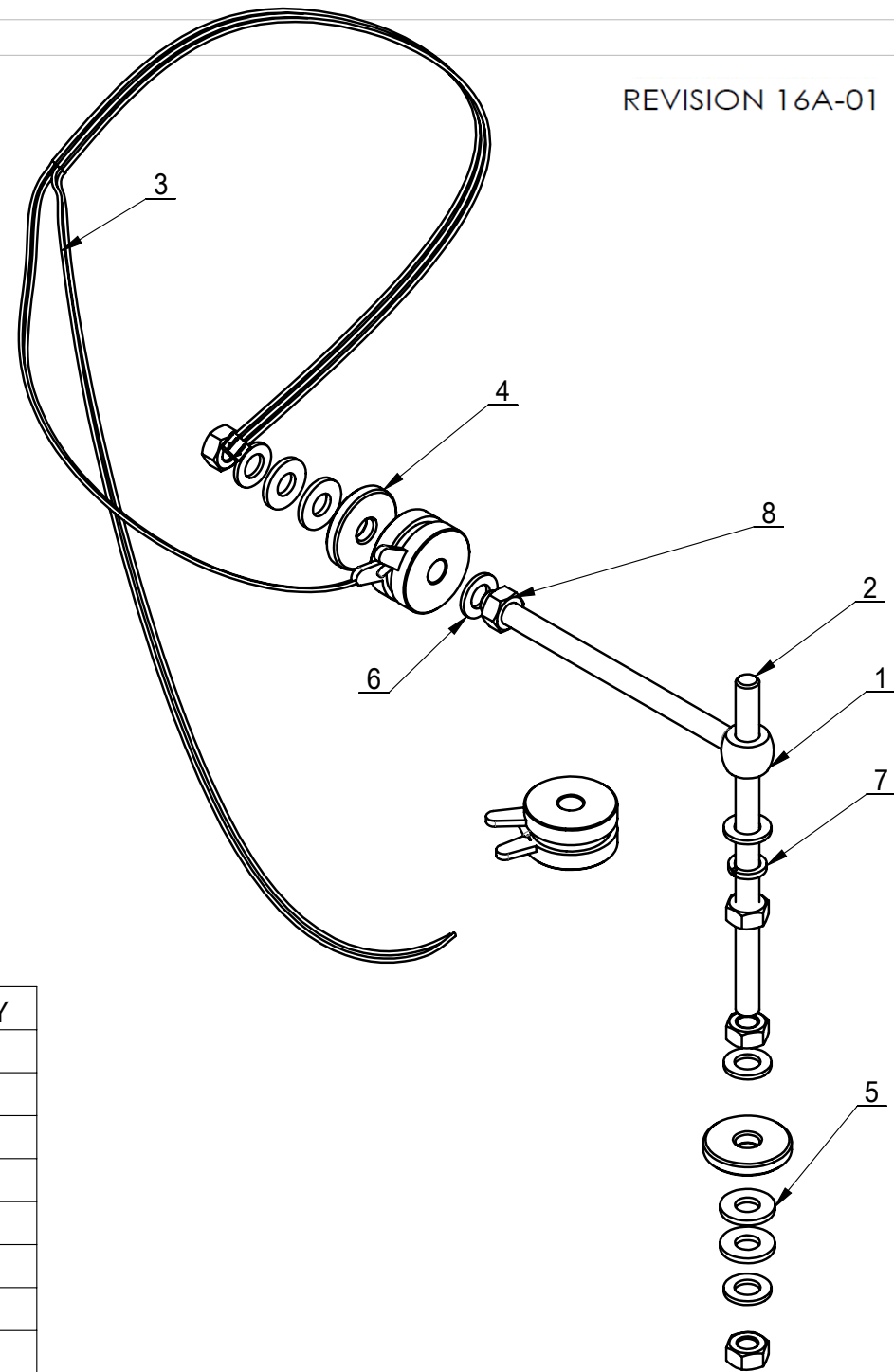

ITEM	PART.No	DESCRIPTION.	QT.Y
1	TB-P-0103000	GONG RINGS BOLT	1
2	TB-P-0100006	FULL BOTTON SCREW	1
3	TB-P-0100100	PIEZO ASSEMBLY	1
4	TB-P-0100005	PRESSING WASHER	2
5	DIN 6796 - 10	SPRING PIEZO WAHSER	4
6	GB95-10	FLAT WASHER	5
7	GB93-10	STANDARD SPRING WASHER	1
8	GB6170-M10	HEXANGULAR NUT 1-TYPE	5

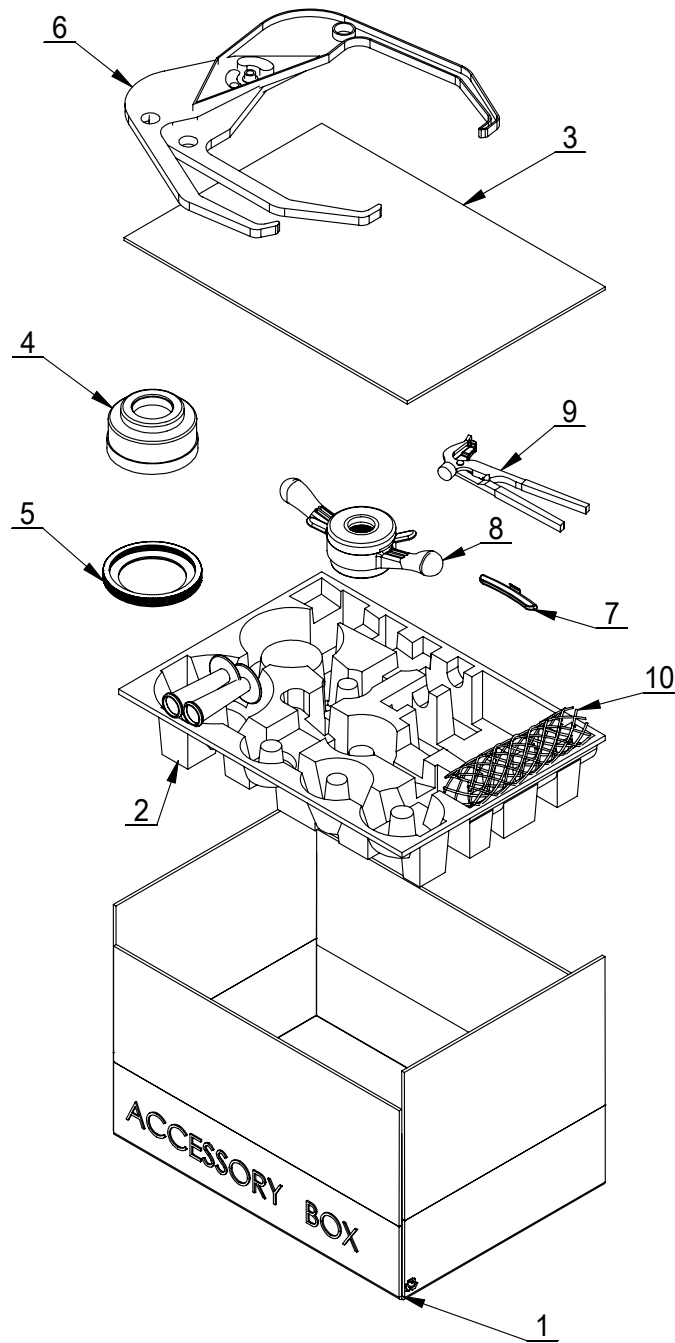

ITEM	PART NO.	Description.	QTY.
1	TB-S-0100006	ACCESSORY BOX	1
2	TB-S-0100007	TRAY	1
3	TB-S-0100008	ACCESSORY SPACE	1
4	TB-S-0100001	BOWL	1
5	TB-S-0100002	BOWL EDGE	1
6	TB-S-0100100	CALIPER ASSEMBLY	1
7	TB-S-0100003	WEIGHT (100g)	1
8	TB-K-0100000	QUICK NUT	1
9	TB-S-0100005	BALANCE HAMMAR	1
10	TB-S-0100012	Protect	1