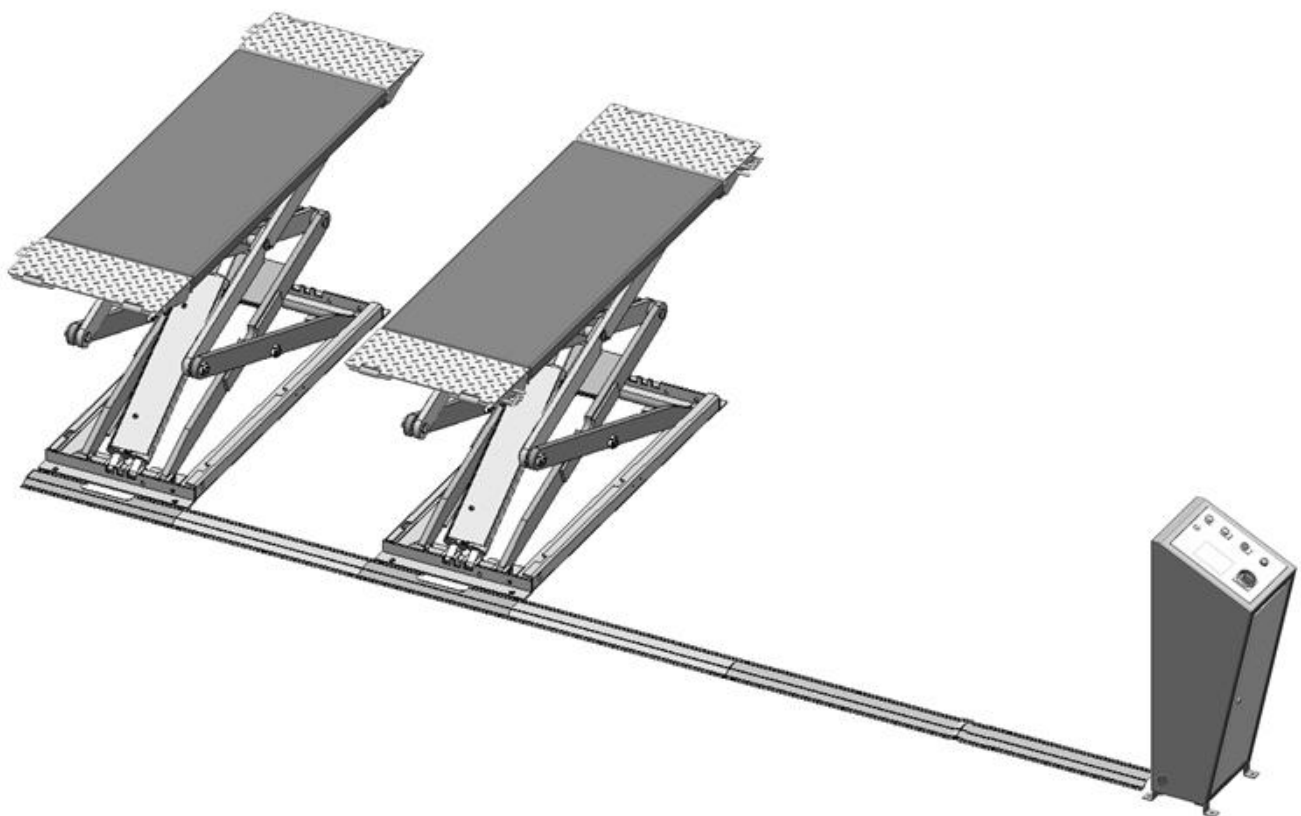




Original

# Installation And Service Manual



**On-Surface Scissors Lift**

**Model: SX07**

# CONTENTS

Product Features and Specifications .....	1
Installation Requirement .....	3
Steps of Installation .....	4
Exploded View .....	15
Test Run .....	24
Operation Instruction .....	25
Maintenance .....	26
Trouble Shooting .....	29
Lift disposal .....	29

**I. PRODUCT FEATURES AND SPECIFICATIONS  
ON SURFACE SCISSORS LIFT MODEL SX07**

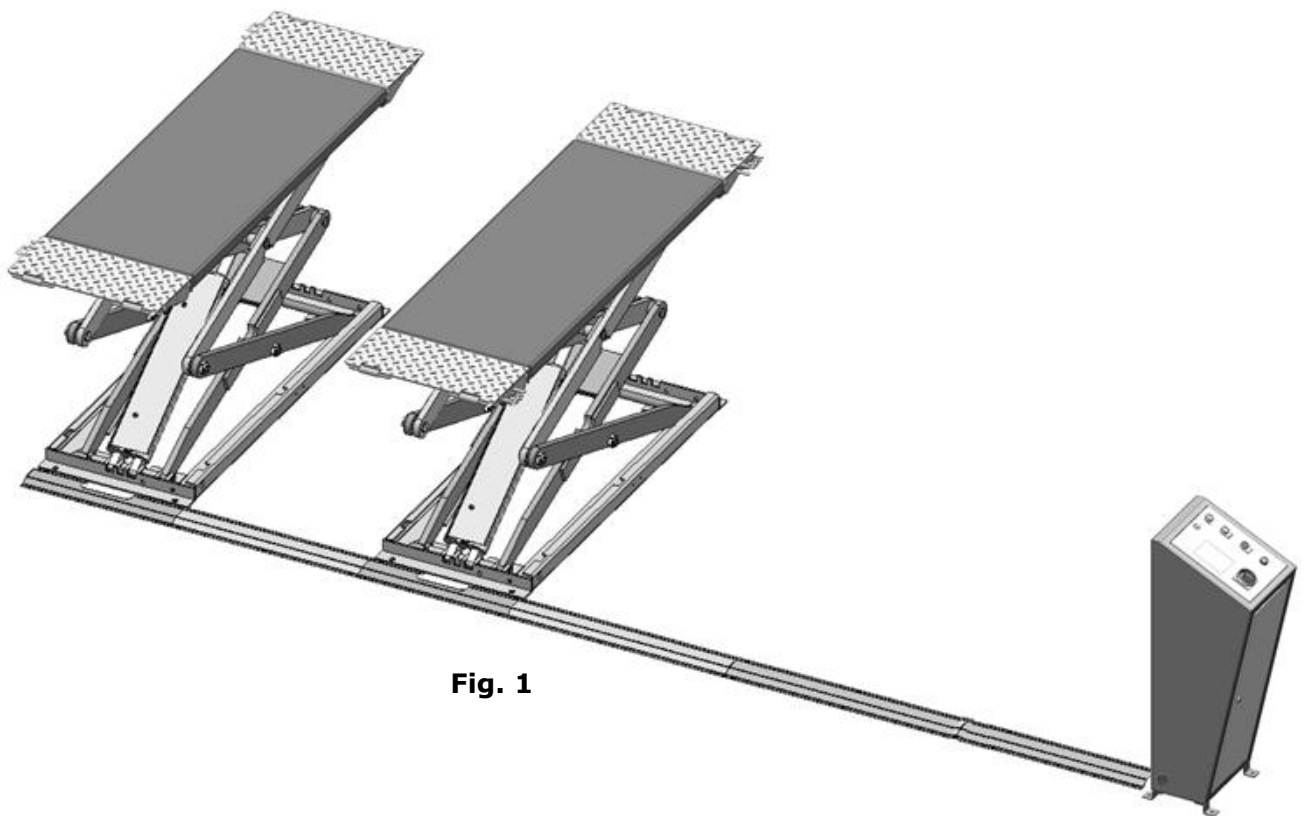
- Electric/Hydraulic power system
- Hose burst check valve and hydraulic self-lock system
- 2-Dual synchronous cylinders are applied to assure the lifting level on both platforms
- Flow control valve to ensure the stable down speed
- Movable drive-thru ramps and extended platforms accommodate varying wheelbase vehicles

**MODEL SX07 SPECIFICATIONS**

Model	Lifting Capacity	Lifting Height	Lifting Time	Overall Length (Inc. ramps)	Overall Width	Min. Height	Runway Width	Width Between Runways	Motor
SX07	3000KG	2000mm	40S	2032mm	1950mm	115mm	600mm	750mm	3.0HP

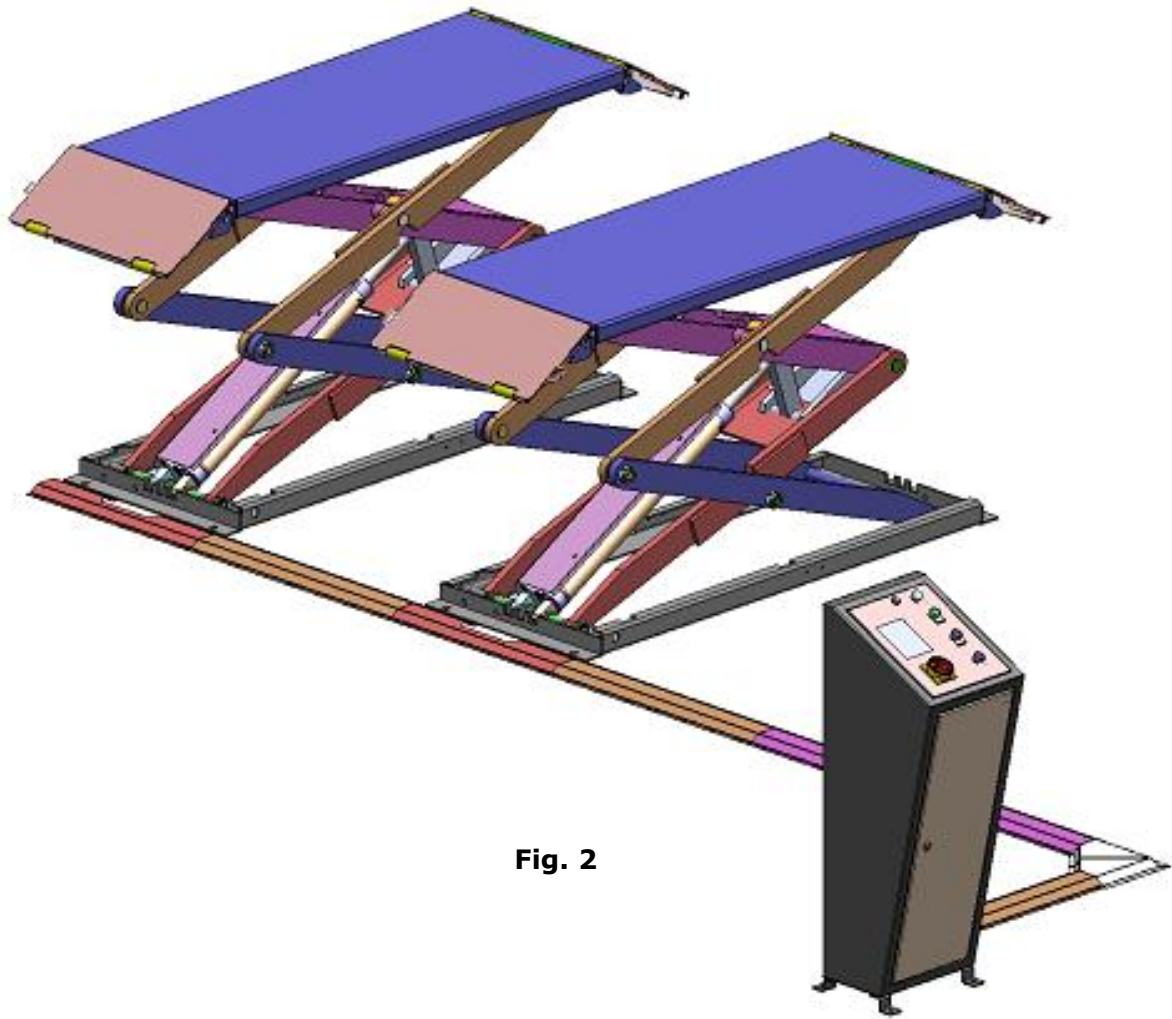
**Illustration of control cabinet installed in different way.**

**View A**



**Fig. 1**

**View B (Other options)**



**Fig. 2**

## II. INSTALLATION REQUIREMENT

### A. TOOLS REQUIRED

- ✓ Rotary Hammer Drill ( $\Phi 19$ ,  $\Phi 10$ ,  $\Phi 4$ )



- ✓ Hammer



- ✓ Level Bar



- ✓ English Spanner (12")



- ✓ Wrench set (8#, 17#)



- ✓ Grease Gun



- ✓ Carpenter's Chalk



- ✓ Screw Sets



- ✓ Tape Measure (7.5m)



- ✓ Pliers



- ✓ Lock Wrench



- ✓ Ratchet Spanner With Socket (28#)



Fig. 3

## **B. Equipment storage and installation requirements.**

The equipment should be stored or installed in a shady, normal temperature, ventilated and dry place.

## **C. The equipment should be unload and transfer by forklift.**



**Fig. 4**

## **D. POWER SUPPLY**

The electrical source must be 2.2KW minimum. The source cable size must be 2.5mm<sup>2</sup> and in good condition of contacting with floor.

## **III. STEPS OF INSTALLATION**

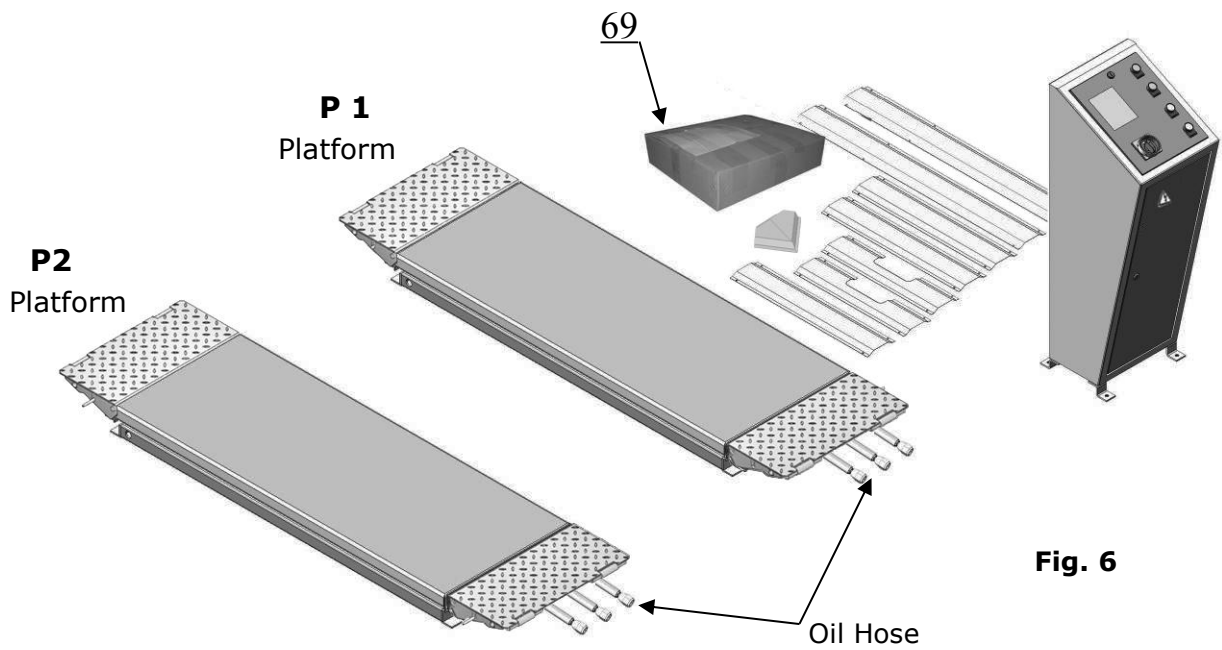
### **A. Check the parts before assembly**

1. Packaged lift, Parts box, Control cabinet and tubing cover plate (**See Fig. 5**).



**Fig. 5**

2. Move aside the parts, open the outer packing and check the parts according to the shipment parts list (**See Fig. 6**).



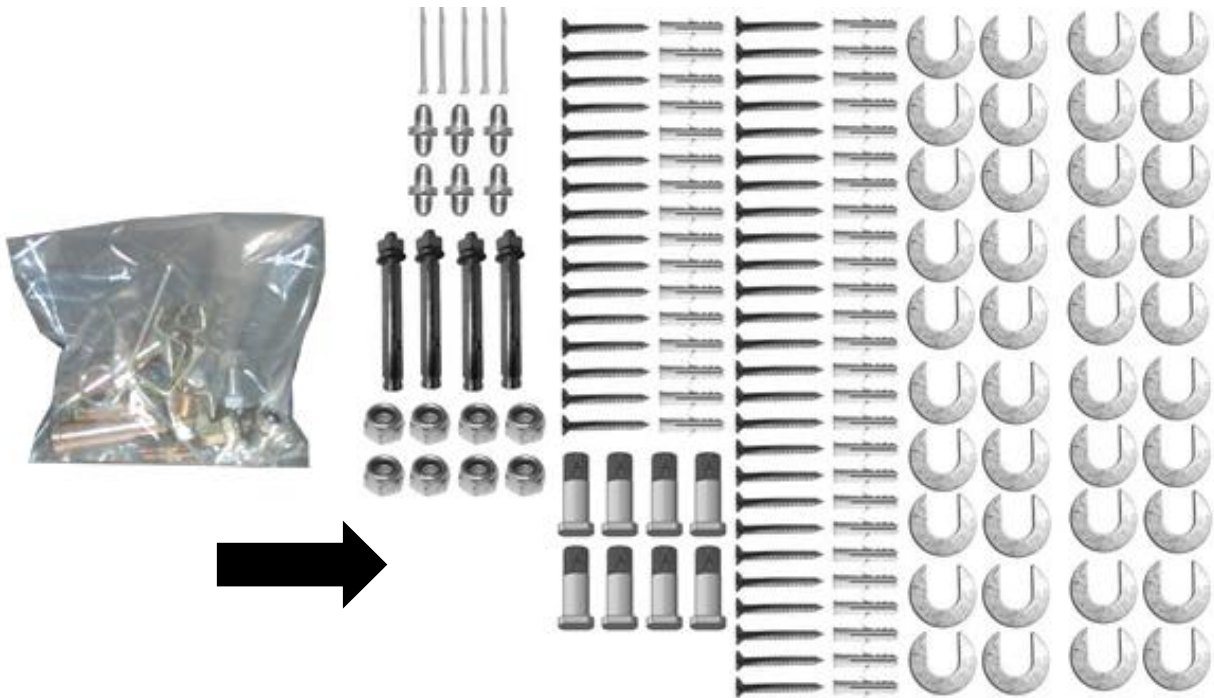
**Fig. 6**

3. Open the parts box, check the parts according to the part list (**See Fig. 7**).



**Fig. 7**

4. Check the parts of the parts bag according to the parts bag list (**See Fig.8**).

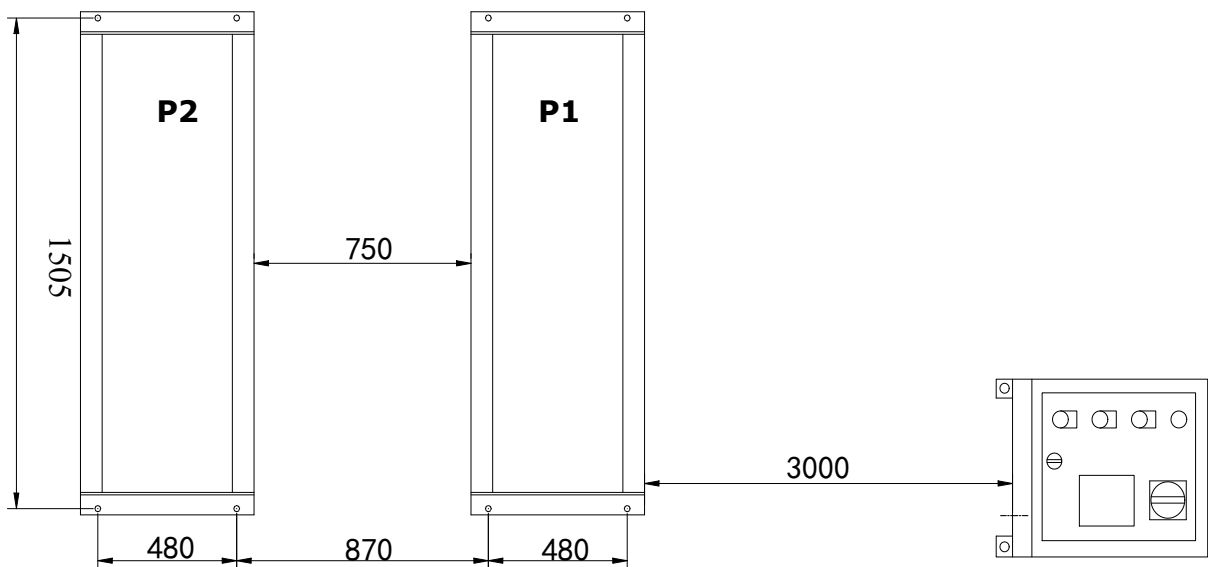


**Fig. 8**

**B. Location of installation**

1. Concrete must be thickness **100mm** minimum and without reinforcing steel bars, and must be dried completely before the installation.
2. Concrete must be in good condition and must be of test strength 3000psi (210kg/cm<sup>2</sup>) minimum.

Review the layout as shown below (**Fig. 9**) and select a location that is best suited for your application.

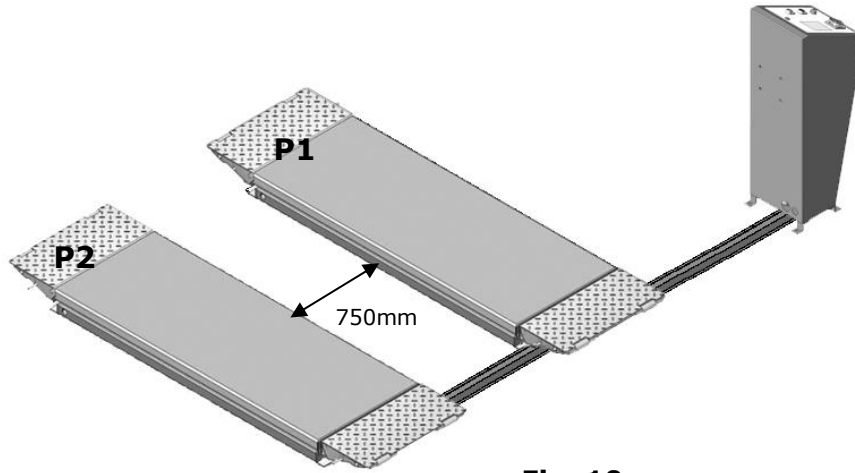


**Fig. 9**

### C. Equipment layout and oil hose installation

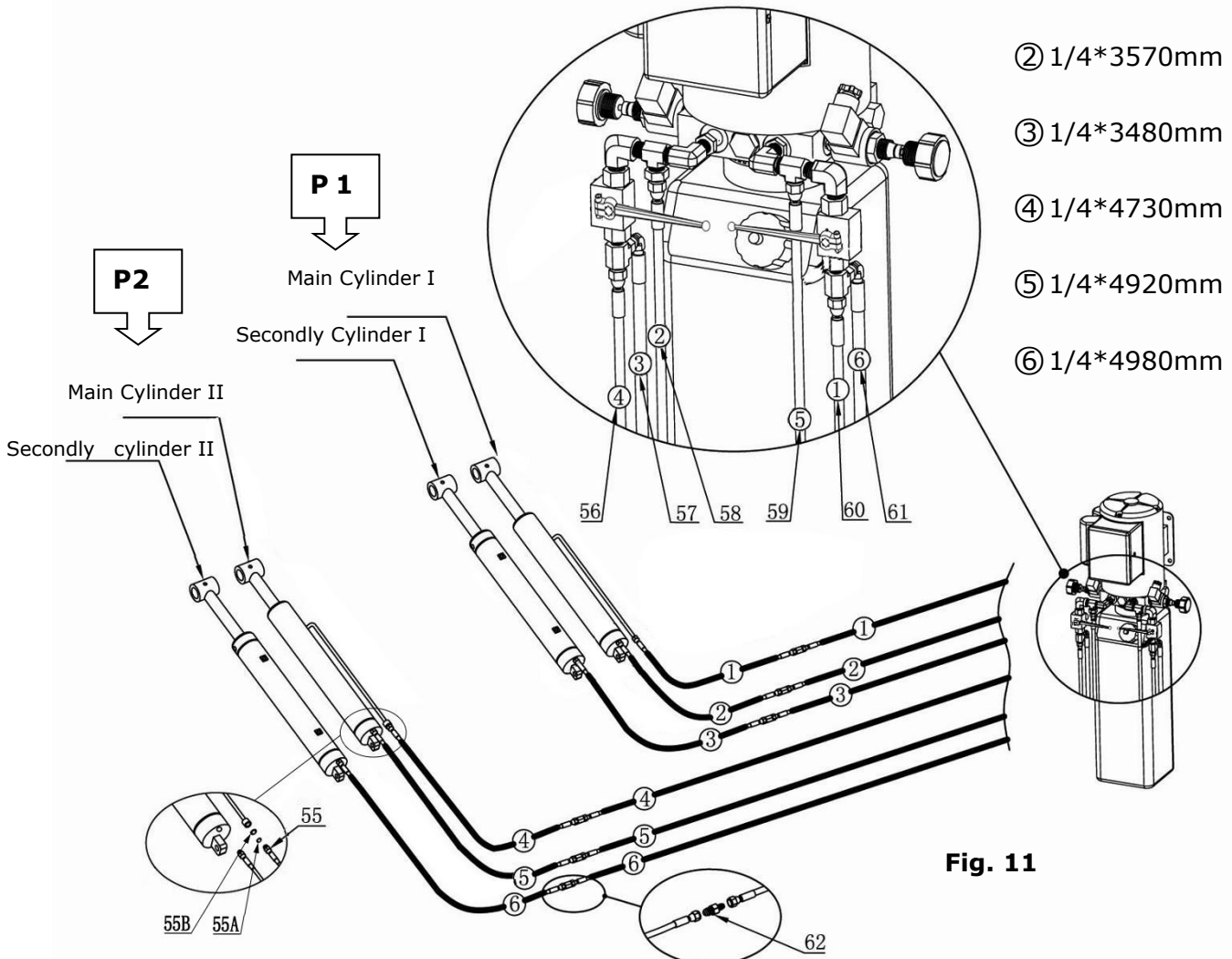
Layout the equipment on the selected location according to **Fig 10**, and connect the oil hose according to **Fig.11**.

Note: Shutoff valves should be at the working condition as showed.



**Fig. 10**

#### Oil hose installation



## D. Install electric system

### 1. Wire connection for hydraulic power unit (for 380V/3 phase motor)

1.1 Connect the power wire and limit switch wire according to the wiring diagram (See Fig. 11).

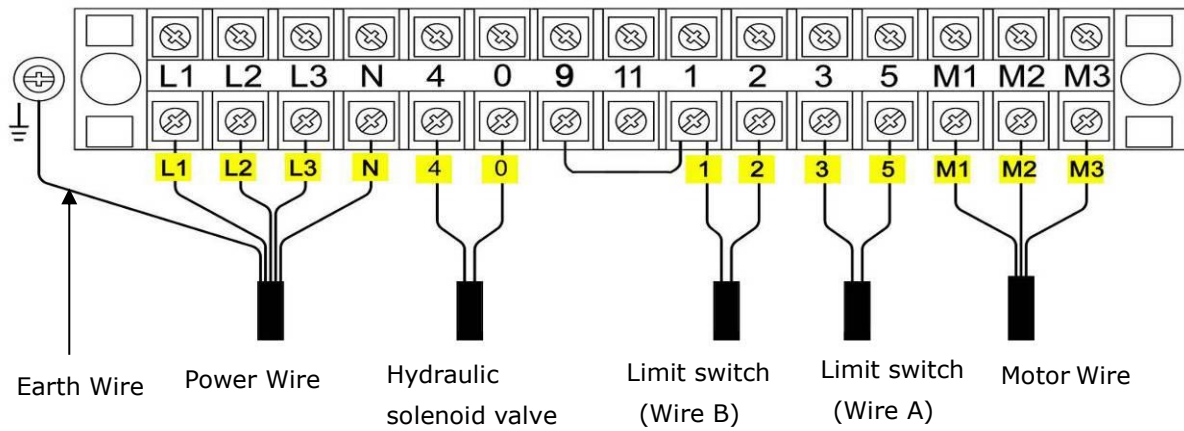


Fig. 12

1.2 Circuit Diagram (See Fig. 13).

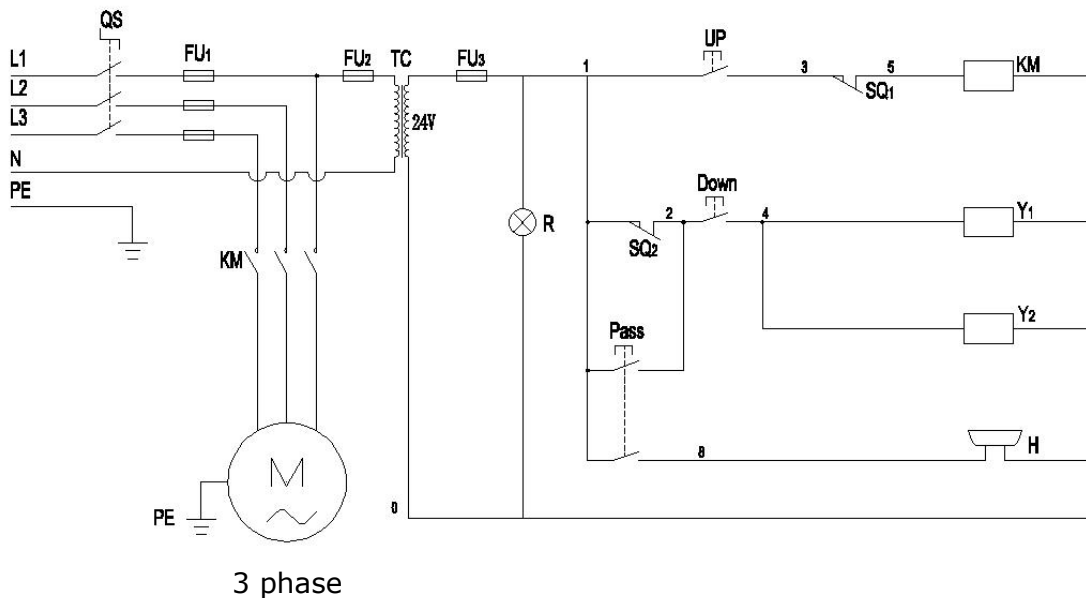


Fig. 13

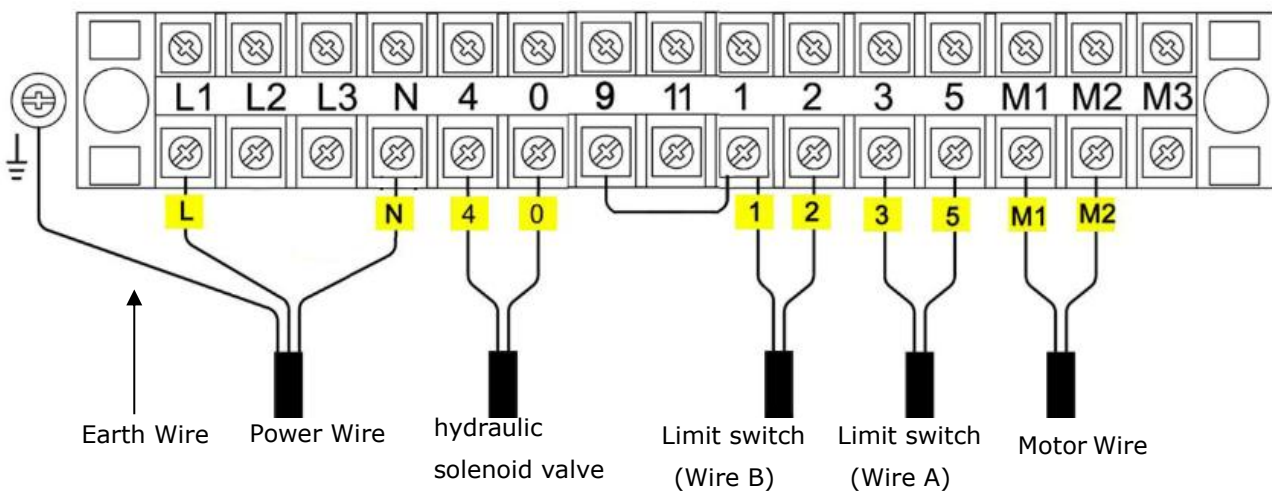
## Electric Component

Item	Name	Code	Specification
1	Power switch	QS	380V AC
2	Breaker	FU <sub>1</sub>	2P
3	Breaker	FU <sub>2</sub>	1P
4	Breaker	FU <sub>3</sub>	1P
5	AC contactor	KM	24V AC
6	Limit switch	SQ <sub>(1~2)</sub>	10A
7	Hydraulic solenoid valve (Right)	Y <sub>2</sub>	AC 24V
8	Hydraulic solenoid valve (Left)	Y <sub>1</sub>	AC 24V
9	Push button	UP	Single
10	Push Button	Down	Single
		Lower Alarm	Duplex
11	Motor	M	3 phase
12	Transformer	TC	24V AC
13	Alarm	H	24V AC
14	Power Indicator	R	24V AC

## 2. Wire connection for hydraulic power unit (for 220V/Single phase motor)

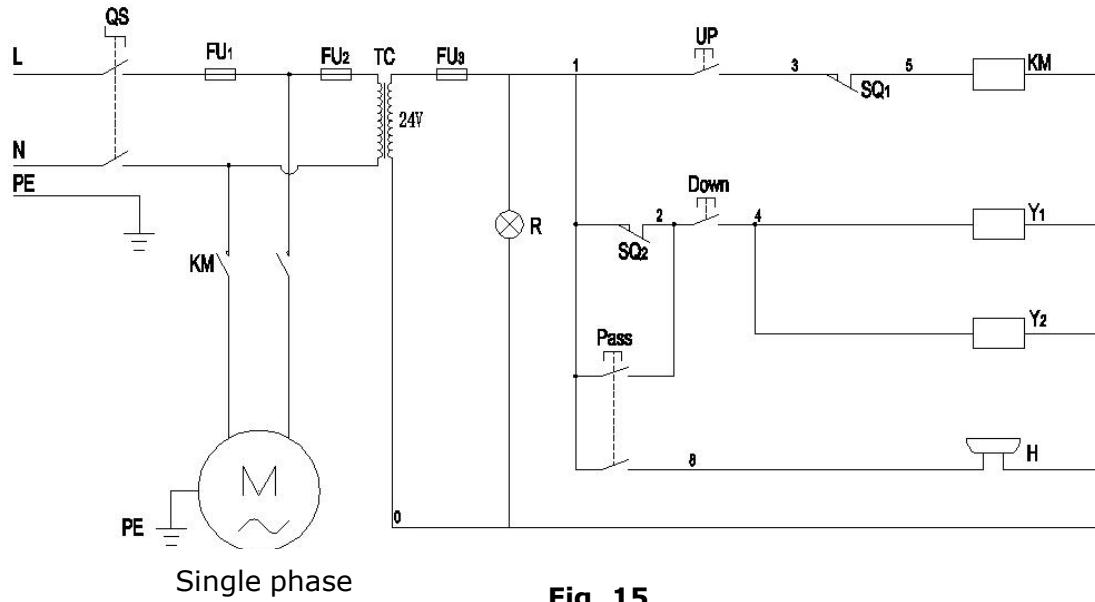
2.1 Connect the power wire and limit switch wire according to the wiring diagram (See

**Fig. 14).**



**Fig. 14**

## 2.2 Circuit Diagram (See Fig. 15).



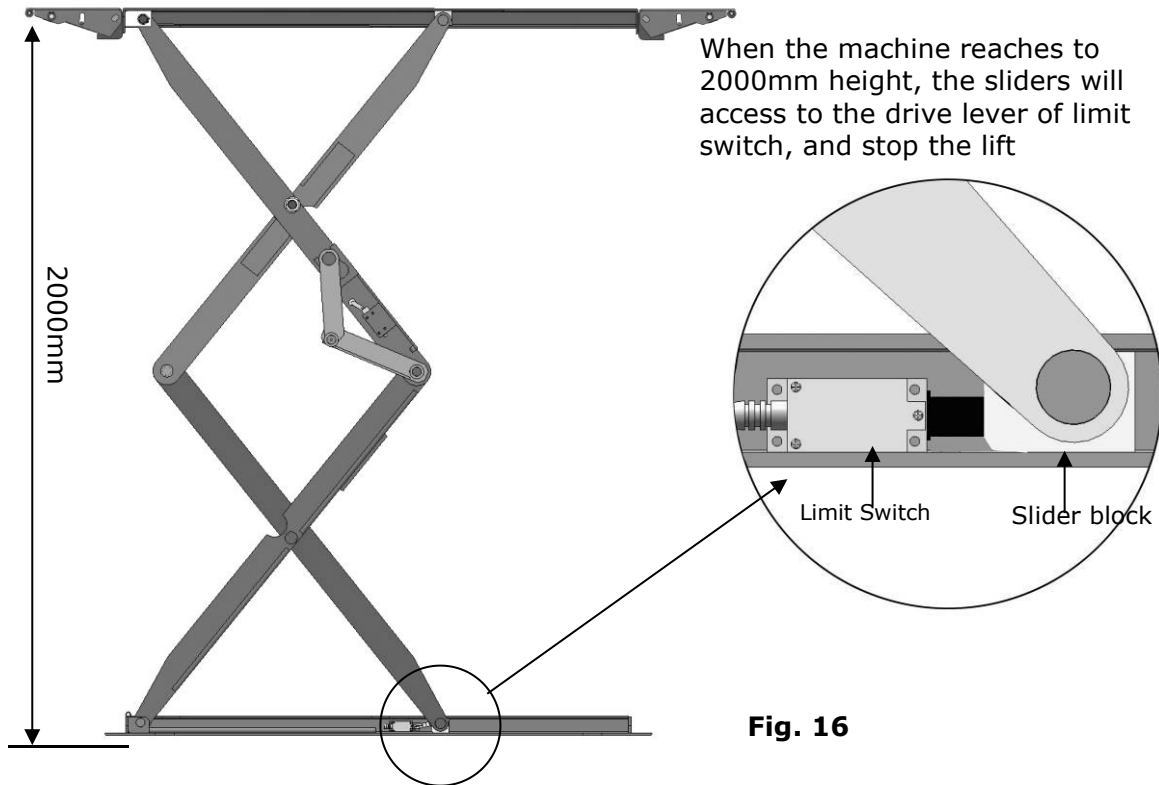
**Fig. 15**

### Electric Component

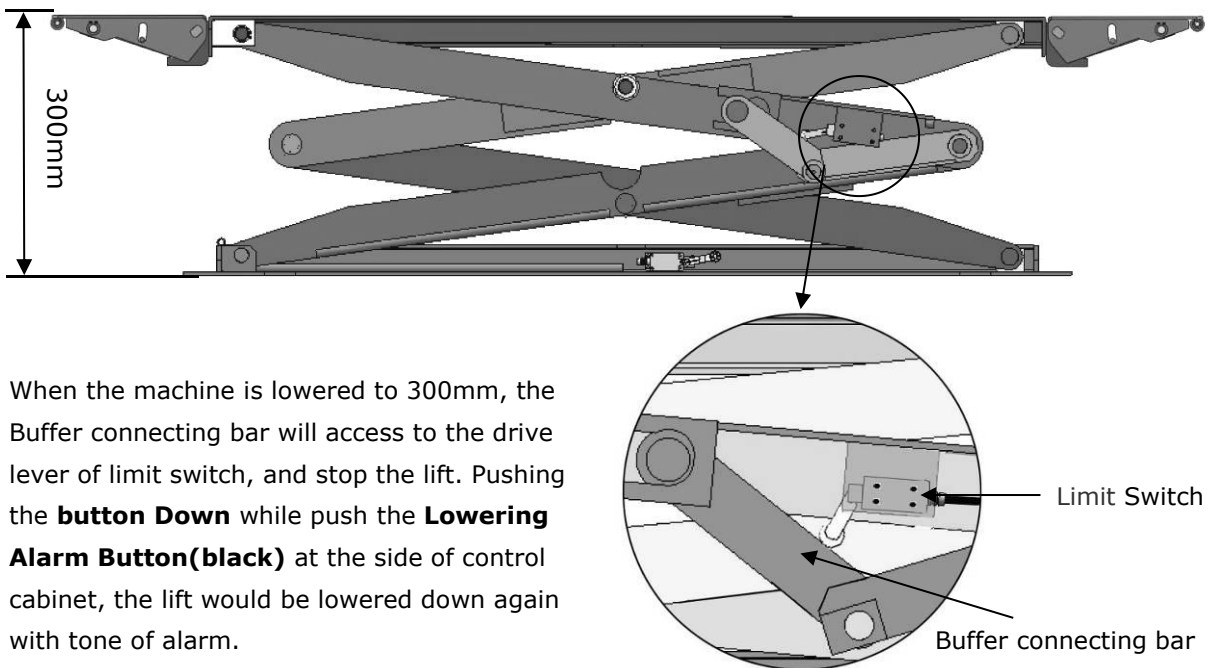
Item	Name	Code	Specification
1	Power switch	QS	380V AC
2	Breaker	FU <sub>1</sub>	2P
3	Breaker	FU <sub>2</sub>	1P
4	Breaker	FU <sub>3</sub>	1P
5	AC contactor	KM	24V AC
6	Limit switch	SQ <sub>(1~2)</sub>	10A
7	Hydraulic solenoid valve (Right)	Y <sub>2</sub>	AC 24V
8	Hydraulic solenoid valve (Left)	Y <sub>1</sub>	AC 24V
9	Push button	Down	Single
		Lower Alarm	Duplex
10	Push Button	Up	Single
11	Motor	M	Single phase
12	Transformer	TC	24V AC
13	Alarm	H	24V AC
14	Power Indicator	R	24V AC

### 3. Limit switch installation instruction

#### 3.1 High limit switch instruction (See Fig. 16)



#### 3.2 Lower alarm device instruction (See Fig.17)



## E. Level two platforms and install anchor bolts

1. Check by level bar and use the shim to adjust the platforms until two platforms are in the same level.

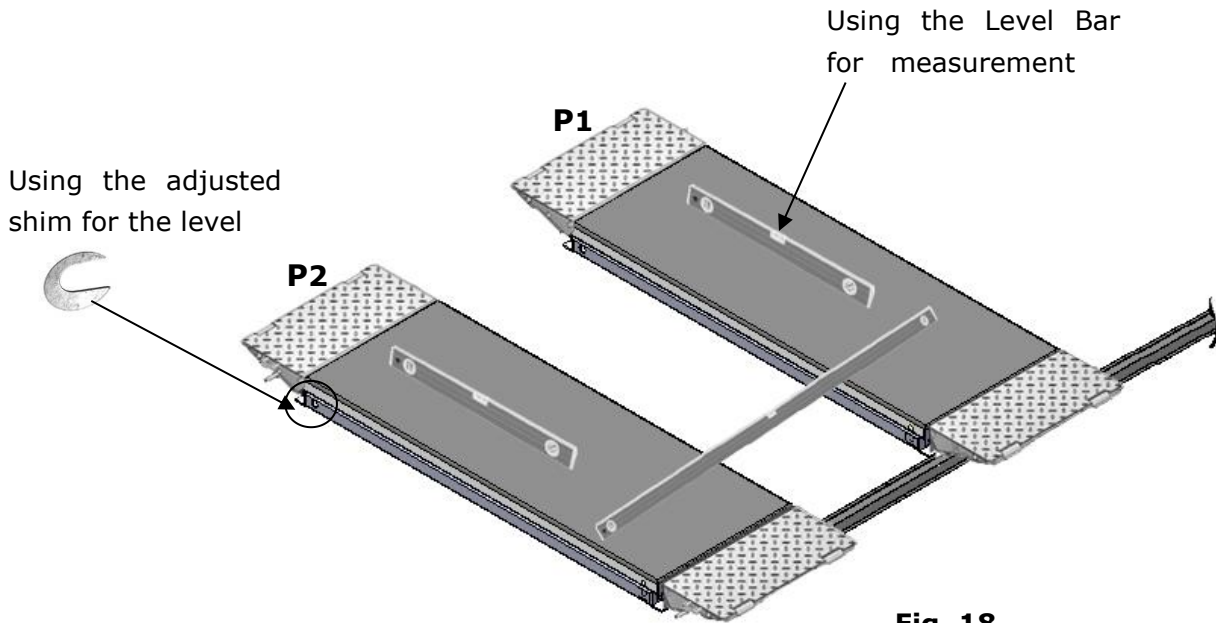


Fig. 18

### 2. Anchor bolts installation

- 2.1 Lift the machine to 1000mm for the anchor bolt installation.

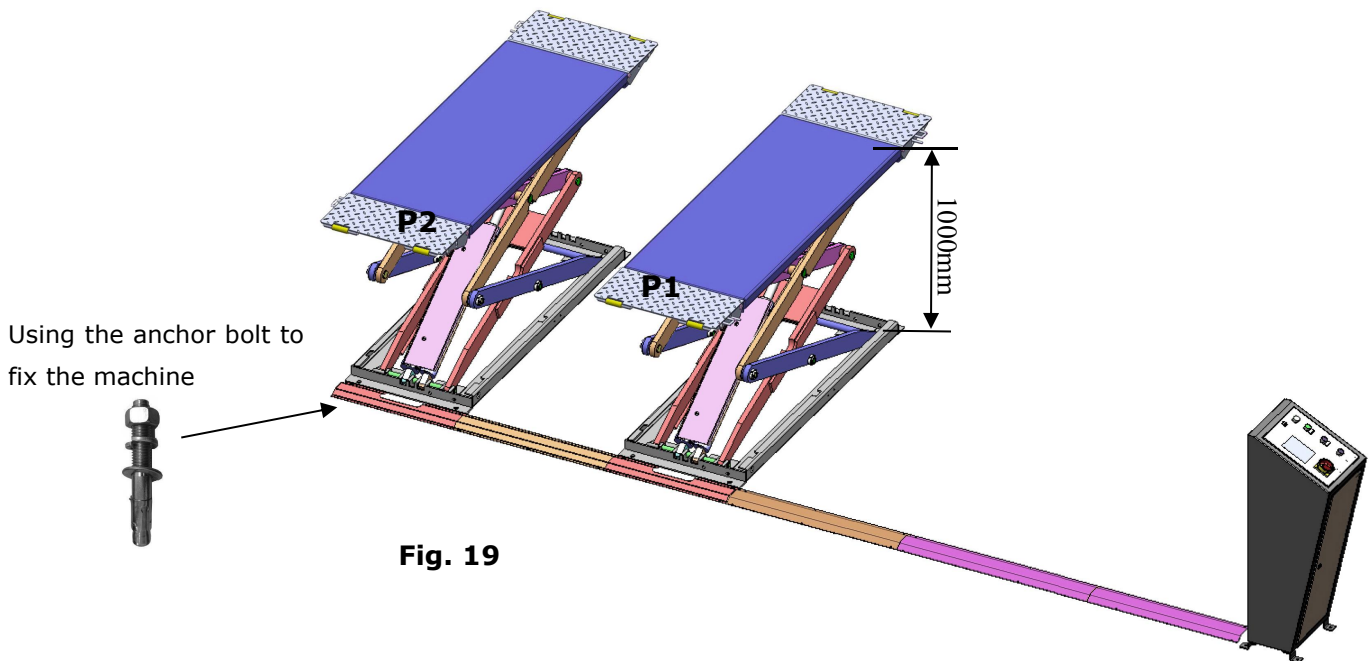
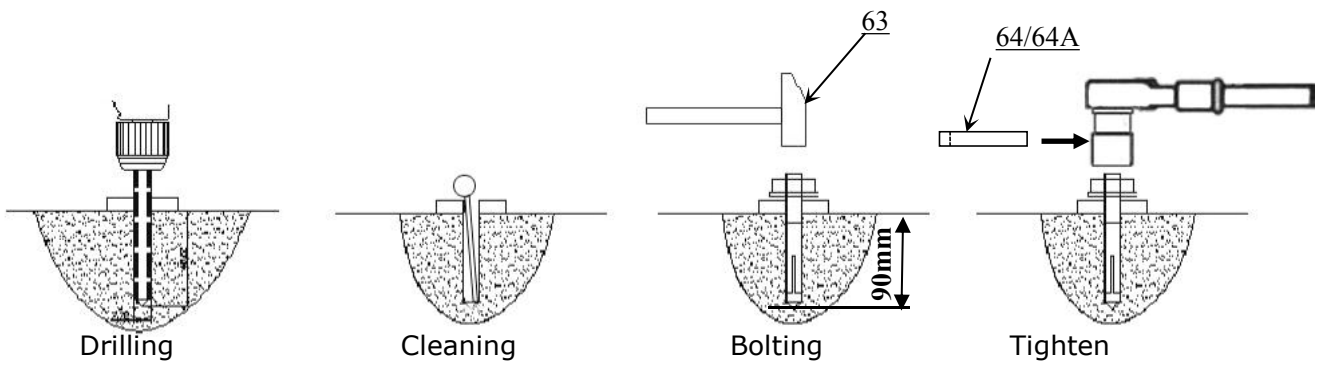


Fig. 19

2.2 Drilling the hole for the anchor bolt with the rotary hammer drill, type the anchor bolt into the ground, and then fasten it with Ratchet spanner.

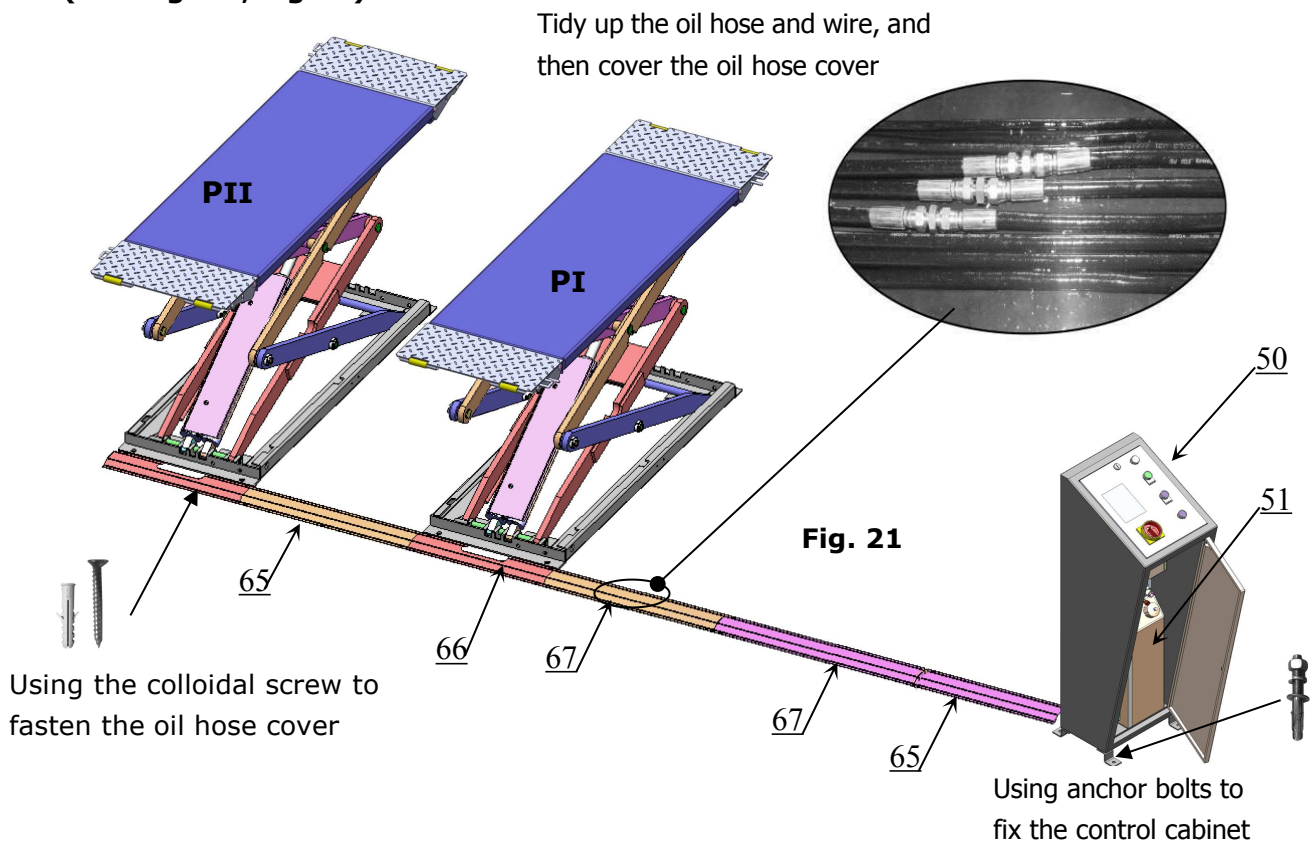
**Note: The Torque of anchor bolt is 150 N.m, the length inside ground of anchor bolt must be over 90mm.**



**Fig. 20**

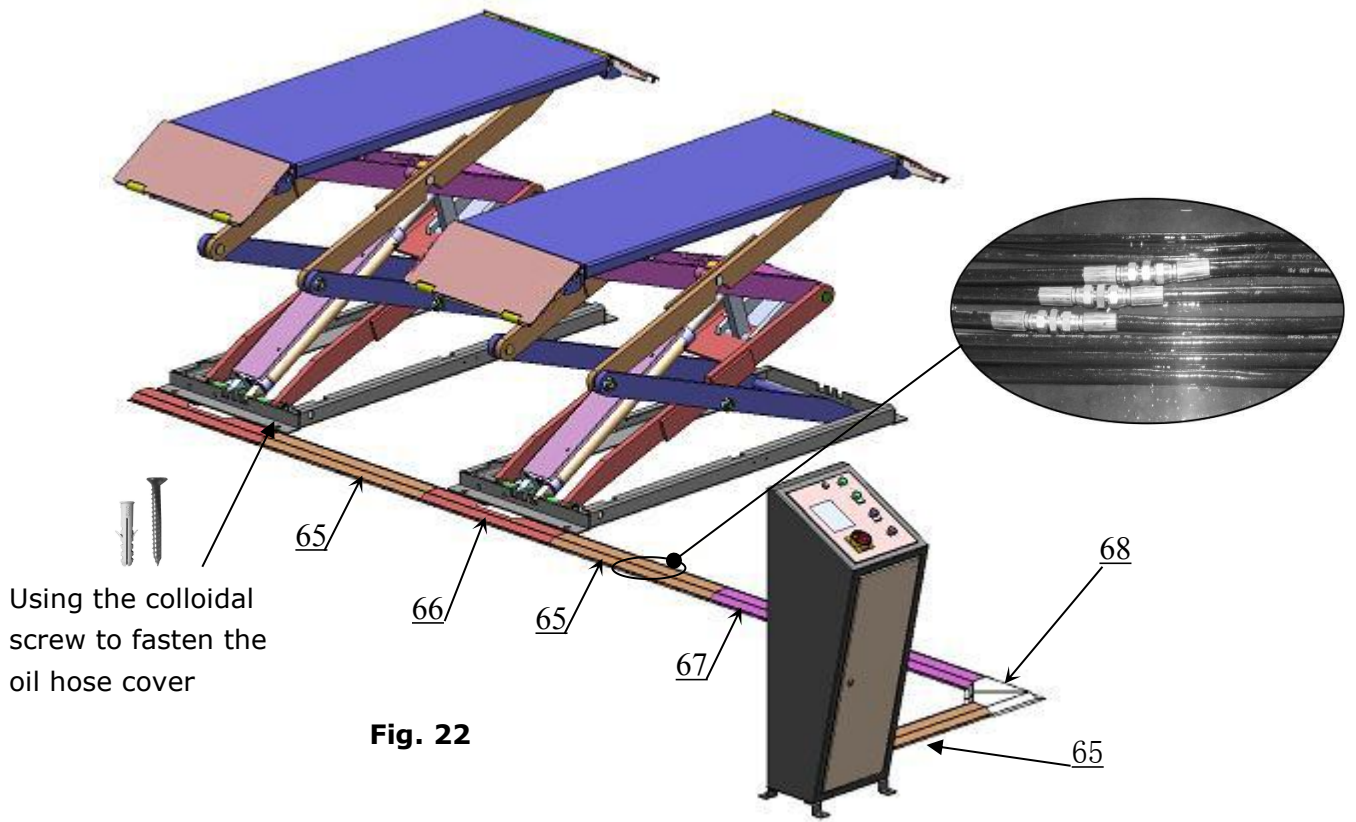
**F. Install oil hose cover and anchor the control cabinet**

1. Tidy up the oil hose and wire, cover the oil hose cover and layout the control cabinet.  
**(See Fig. 21, Fig 22)**

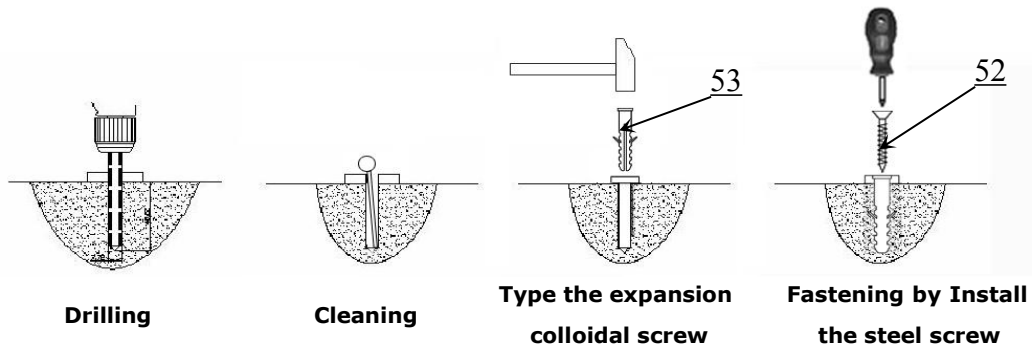


**Fig. 21**

**View B Installation**



2. Install the colloidal screw of oil hose cover (See Fig. 23).



**Fig. 23**

3. Install the control cabinet anchor bolt (See Fig. 24)

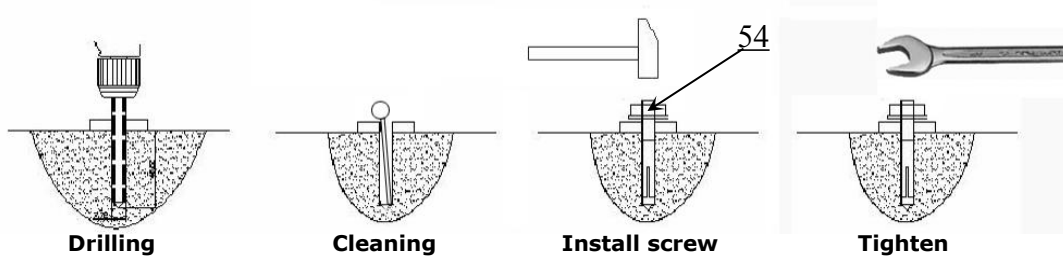


Fig. 24

IV. EXPLODED VIEW

MODEL SX07

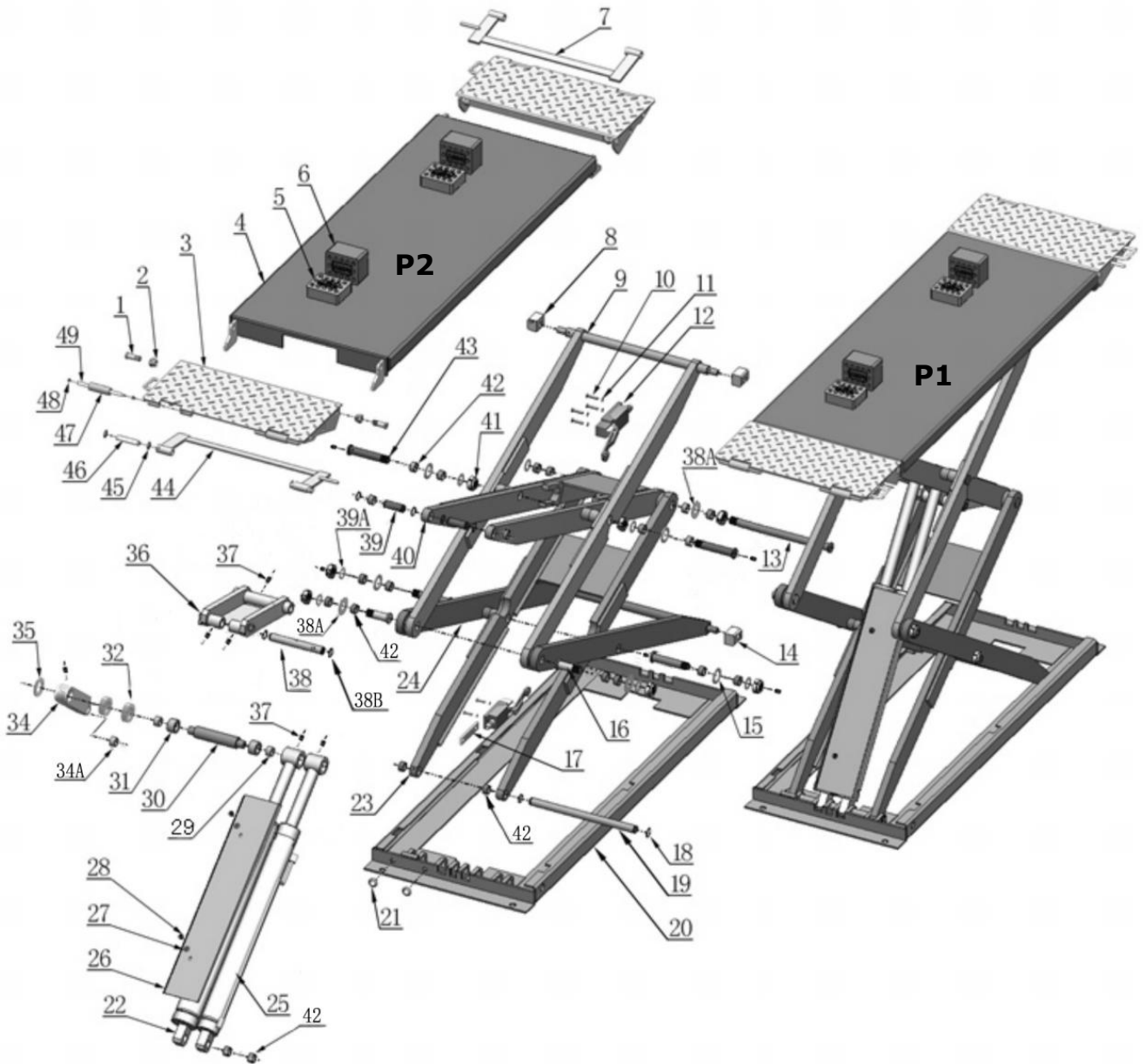


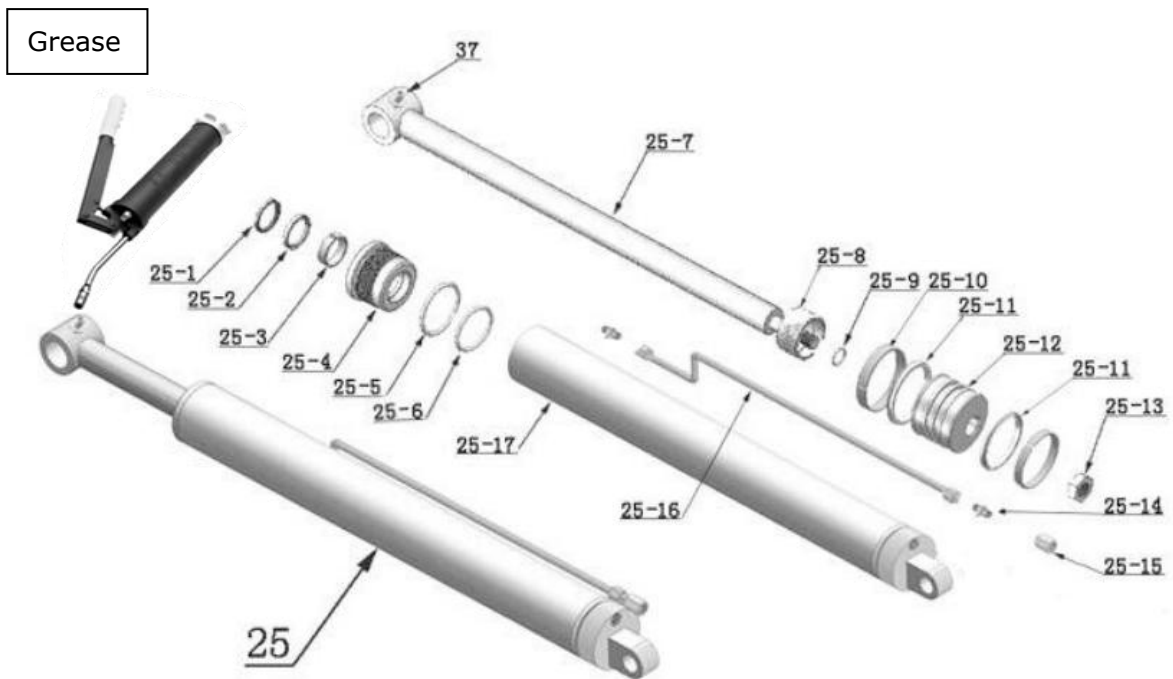
Fig. 25

## PARTS LIST FOR SX07

Item	Part#	Description	QTY.	Note
1	11620124	Pin For Drive-thru Ramp	8	
2	10650024	Self locking nut M16	8	
3	11620128	Drive-in Ramp	4	
4	11620001B	Platform	2	
5	10620034	Rubber Pad 120*100*38	4	
6	10610070	Rubber Pad 120*100*70	4	
7	11620129	Support frame for Drive-in Ramp (Left)	2	
8	1003105001	Slider Block (white) 60*42*23	4	
9	11620026B	Upper Scissor (Outter)	2	
10	10203018	Socket Bolt M5*15	6	
11	10420152	Washer $\phi$ 5	6	
12	10206013	Limit Switch	2	
13	11620011A	Scissors Pin $\phi$ 25*370	2	
14	10620061	Slider Block (white) 33*42*80	4	
15	10620117	Washer	8	
16	11620030	Scissors Pin $\phi$ 35*83	4	
17	11620060	Fix Plate For Limit Switch	1	
18	10206032	Snap Ring $\phi$ 25	12	
19	11620014A	Base frame Pin $\phi$ 25*392	2	
20	11620017B	Base frame	2	
21	10620059	Protection Ring (Groove width 6mm)	3	
22	10620186	Secondly Cylinder $\phi$ 60*560	2	
23	11620033A	Lower Scissor (Inner)	2	
24	11620031A	Lower Scissor (Outer)	2	
25	10620012B	Main Cylinder $\phi$ 75*560	2	
26	11620016A	Cylinder Cover	2	
27	10420045	Washer $\phi$ 6	4	
28	10209009	Cup Head Bolt M6*8	4	
29	10620180	Bronze Bush $\phi$ 30* $\phi$ 38*25	4	
30	11620025A	Cylinder Connecting Pin $\phi$ 38*221	2	
31	11620024A	Roller $\phi$ 52*25	4	
32	11620120	Pin Bush $\phi$ 60*17mm	4	
34	11620007A	Buffer Connecting bar	2	
34A	10620141	Bronze Bush $\phi$ 36* $\phi$ 30.1*24	2	
35	11620119	Pin Bush $\phi$ 60*5.5mm	2	
36	11620010B	Buffer	2	
37	10620064	Greasing Fitting M6	28	
38	11620008A-01	Buffer Connecting Pin $\phi$ 30*192	2	
38A	1003105003	Slider pad $\phi$ 65* $\phi$ 25.5*8	8	
38B	10610008	$\phi$ 30 Snap ring	4	
39	11620028A	Connecting Pin (Platform) $\phi$ 25*72	4	
39A	10640109	Washer $\phi$ 44* $\phi$ 25.5*2	14	

Item	Part#	Description	QTY.	Note
40	11620027B	Upper Scissor (Inner)	2	
41	10620022	Self locking Nut M24*2.5	14	
42	10203004A	Bronze Bush $\phi 31 * \phi 25.1 * 21$	44	
43	11620019A	Scissors Pin $\phi 35 * 137$	8	
44	11620130	Support frame for Drive-in Ramp(Right)	2	
45	10420037	Snap Ring $\phi 16$	16	
46	11620123	Connecting Shaft for support frame $\phi 16 * 90$	8	
47	11610667	Roller for Drive-in Ramp	8	
48	10209010	$\phi 10$ Snap Ring	16	
49	11620043	Roller Pin	8	
50	10620199	Control Cabinet (Single phase)	1	
	10620067	Control Cabinet (Three phase)		
51	81523008	Electric Power Unit (220V/50Hz)	1	
	81523007	Electric Power Unit (380V/50Hz)		
52	10620069	Screw M4*30	42	
53	10620070	Colloidal screw $\phi 6$	42	
54	10620071	Anchor Bolt M10*100	4	
55	10620072	Oil Hose 1/4*650mm	6	
55A	10620103	O Ring $\phi 11 * 2.5$	6	
55B	10620102	Seal Ring $\phi 16 * \phi 19 * 1.8$	6	
56	10620152	Oil Hose No.④ 1/4*4730mm	1	
57	10620153	Oil Hose No.③ 1/4*3480mm	1	
58	10620154	Oil Hose No.② 1/4*3570mm	1	
59	10620155	Oil Hose No.⑤ 1/4*4920mm	1	
60	10620156	Oil Hose No.① 1/4*3720mm	1	
61	10620157	Oil Hose No.⑥ 1/4*4980mm	1	
62	10620079	Straight Fitting 1/4JIC(M)*1/4JIC(M)	6	
63	10209059	Anchor Bolt 3/4*5-1/2	8	
64	10620065	Shim (2mm)	20	
64A	10201090	Shim (1mm)	20	
65	11620035A	Oil hose cover (748mm)	3	
66	11620066	Oil hose cover (600mm)	2	
67	11620036A	Oil hose cover (1060mm)	2	
68	11620161	Oil hose cover	1	
69	10620500A	Parts Box	1	

#### 4.1 Main CYLINDERS (10620012B)



**Fig 26**

#### Parts for Main cylinder

Item	Part#	Description	QTY.	Note
25-1	10209078	Dust Ring	4	
25-2	10217243	Y- Ring	2	
25-3	10620047	Support Ring	2	
25-4	11620192	Head Cap (Main)	2	
25-5	10620171	O- Ring	2	
25-6	10630027	O-Ring	2	
25-7	11620051	Piston Rod	4	
25-8	11620193	Spacer For Cylinder	2	
25-9	10620197	O- Ring	4	
25-10	10620053	Support Ring	2	
25-11	10620054	Y- Ring	4	
25-12	11620194	Piston	2	
25-13	10206071	Hex Nut	4	
25-14	10209064	Straight fitting	4	
25-15	10620127	Oil hose fitting	2	
25-16	10620125A	Oil hose ASSY.	2	
25-17	11620050A	Bore weldment	2	

## 4.2. Secondly Cylinders (10620186)

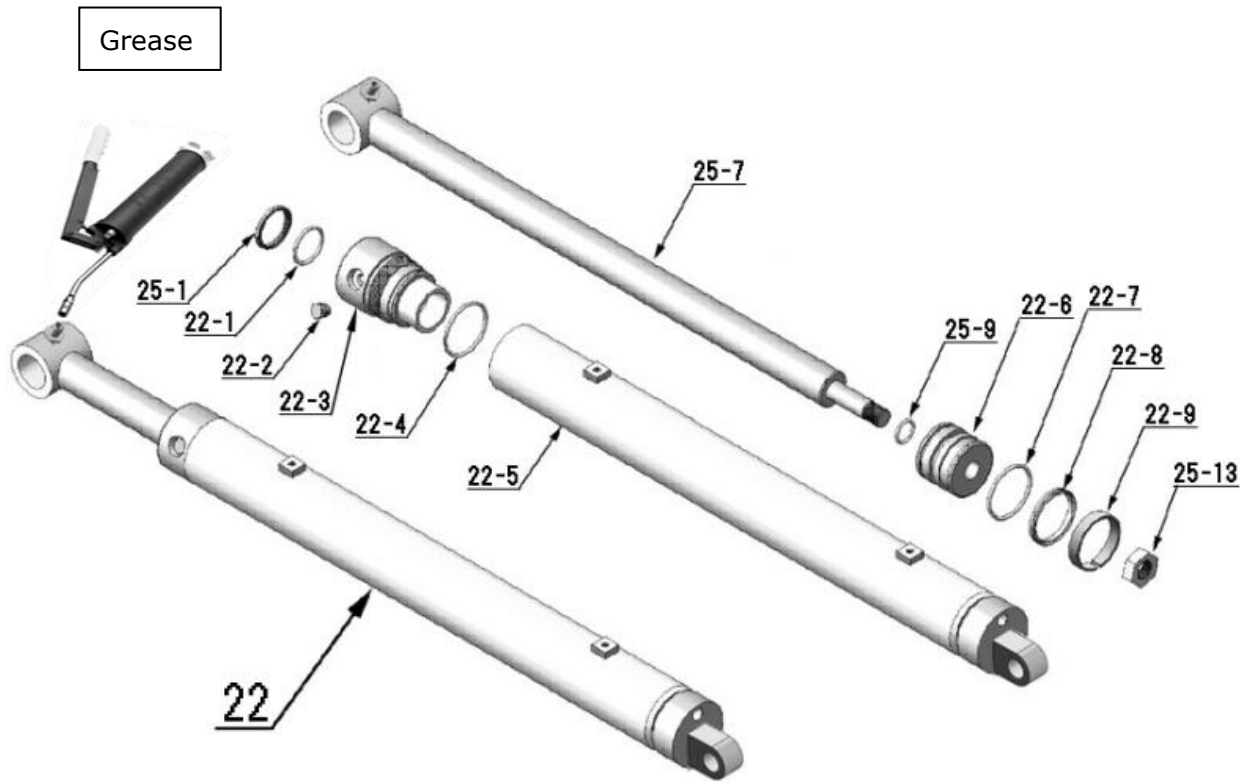


Fig. 27

### Parts for Secondly cylinder

Item	Part#	Description	QTY.	Note
22-1	10520058	O- Ring	2	
22-2	10201034	Bleeding Plug	2	
22-3	11620190	Head Cap	2	
22-4	10620182	O- Ring	2	
22-5	11620056	Bore Weldment	2	
22-6	11620196	Piston	2	
22-7	10217258	O- Ring	2	
22-8	10217257	Y- Ring	2	
22-9	10217256	Support Ring	2	

## CONTROL CABINET

Part No.: 10620199 (Single Phase)

10620067 ( 3 Phase)

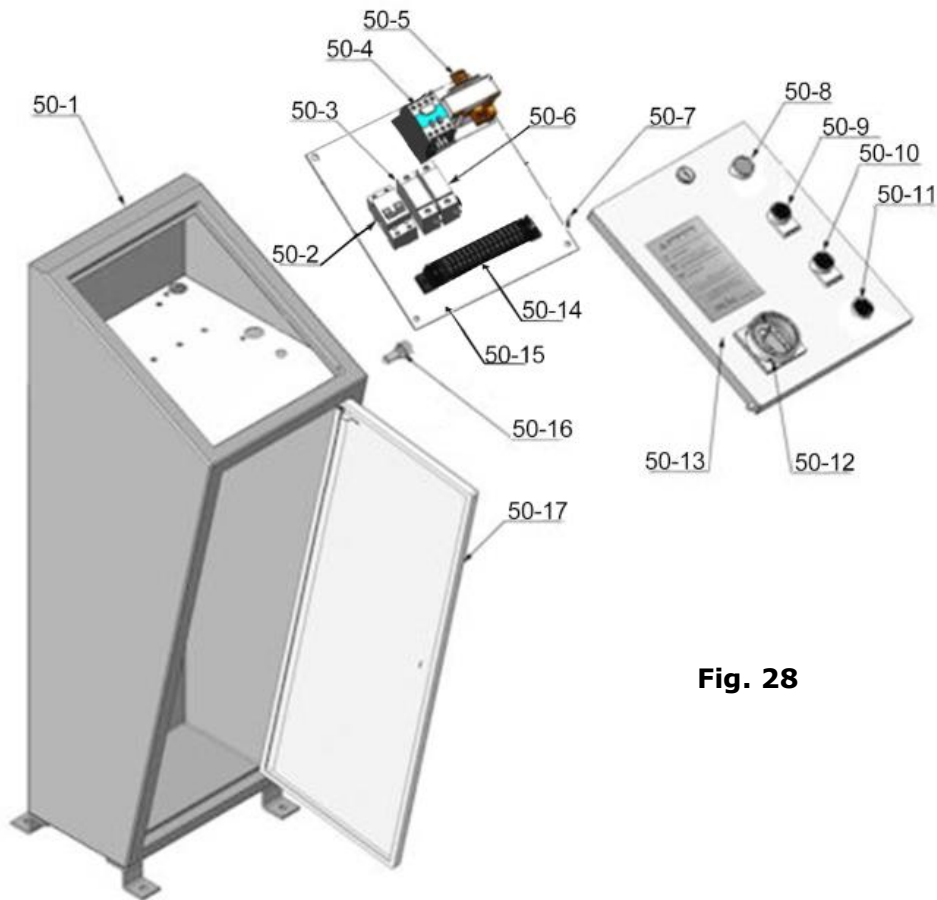


Fig. 28

### Parts for control cabinet

Item	Part#	Description	QTY.	Note
50-1	1162K001A	Cabinet Body	1	
50-2	10620150	Breaker 3P 25A (380V only)	1	
	10202046	Breaker 2P (220V only)	1	
50-3	10202049	Breaker 1P 6A	1	
50-4	10420084A	24V AC Contractor (KM)	1	
50-5	10420134	24V Transformer (TC)	1	
50-6	10202049	Breaker 1P 6A	1	
50-7	1061K052	Cup Head Bolt	4	
50-8	10201094	Power Indicator	1	
50-9	10209099A	Button (UP)	1	
50-10	10209099A	Button (Down)	1	
50-11	10420142	Lower Alarm Button (Pass)	1	
50-12	41010217	Power Switch (QS)	1	
50-13	1162K007	Control Panel	1	
50-14	10620082	Terminal Group	1	
50-15	10620099	Panel for Installing Element	1	
50-16	10420143	Alarm	1	
50-17	1162K012	Door of control cabinet	1	

#### 4.4 ELECTRIC POWER UNIT (81523007/81523008)

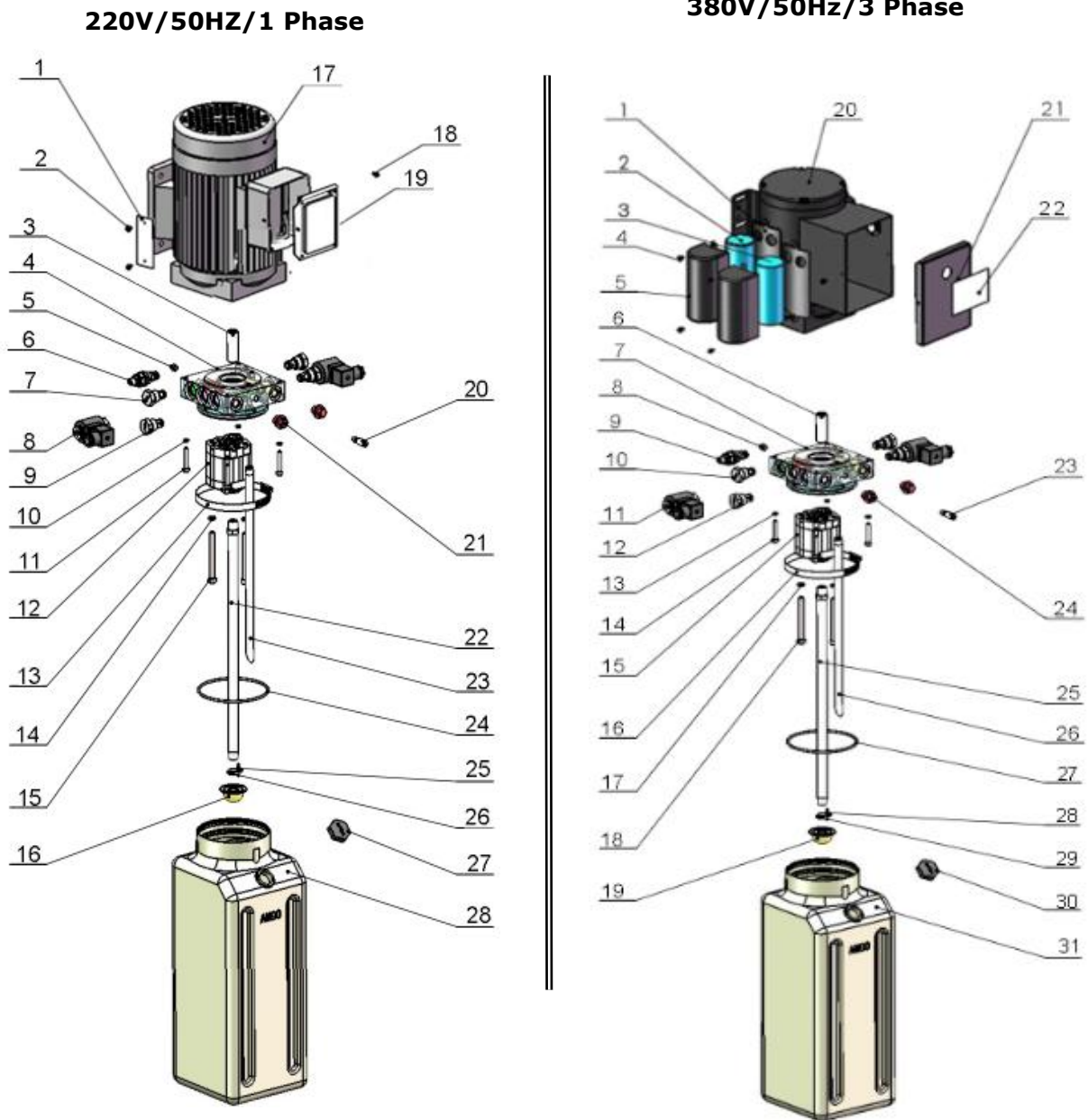


Fig. 29





### Parts for 380V 50Hz 3PH power unit

Item	Part#	Description	QTY.	Note
1	71150055	AMGO Name plate	1	
2	81400300	Cup Head Bolt	2	
3	81400363	Motor Connecting Shaft	1	
4	80101015	Valve Body	1	
5	81400333	Socket Plug	4	
6	81400266	Relief Valve	1	
7	81400566	Check Valve	2	
8	81400420	Hydraulic Solenoid Valve Coil	2	
9	81400423	Release Valve	2	
10	10209149	Lock Washer $\phi 6$	4	
11	85090142	Socket Bolt	4	
12	81400280	Gear Pump	1	
13	81400364	Hose Clamps	1	
14	10209034	Lock Washer $\phi 8$	2	
15	81400295	Socket Bolt	2	
16	81400290	Filter	1	
17	81400286	Aluminum Motor	1	
18	10420148	Cup Head bolt with washer	2	
19	81400208	Terminal Box cover for motor	1	
20	10420148	Cup Head bolt with washer	6	
21	81400209	Terminal Box cover for motor	1	
22	81400560	Throttle Valve	1	
23	81400259	Rubber Plug	2	
24	81400288	Oil Suction Hose	1	
25	81400289	Oil Return Hose	1	
26	81400365	O Ring	1	
27	10209152	Tie	1	
28	85090167	Magnet	1	
29	81400263	Tank Cover	1	
30	81400275	Tank	1	

## Parts for 220V 50Hz 1PH power unit

Item	Part#	Description	QTY.	Note
1	81400180	Rubber Pad	2	
2	81400250	Start Capacitor	1	
3	81400200	Run Capacitor	1	
4	10420148	Cup Head Bolt	6	
5	81400066	Capacitor Cover	2	
6	81400363	Motor Connecting Shaft	1	
7	80101015	Valve Body	1	
8	81400333	Socket Plug	4	
9	81400266	Relief Valve	1	
10	81400566	Check Valve	2	
11	81400420	Hydraulic Solenoid Valve Coil	2	
12	81400423	Release Valve	2	
13	10209149	Lock washer $\phi 6$	4	
14	85090142	Socket Bolt	4	
15	81400280	Gear Pump	1	
16	81400364	Hose Clamps	1	
17	10209034	Lock Washer $\phi 8$	2	
18	81400295	Socket Bolt	2	
19	81400290	Filter	1	
20	81400413	Motor	1	
21	81400287	Terminal Box cover for motor	1	
22	71111231	AMGO Label	1	
23	81400560	Throttle Valve	1	
24	81400259	Rubber Plug	2	
25	81400288	Oil Suction Hose	1	
26	81400289	Oil Return Hose	1	
27	81400365	O Ring	1	
28	10209152	Tie	1	
29	85090167	Magnet	1	
30	81400263	Tank Cover	1	
31	81400275	Tank	1	

## V. TEST RUN


1. Turn on the power after connecting oil system correctly. Push the **UP** button, and check the rotated direction of the Motor (This is right if lift is upward, otherwise, it is wrong direction of the Motor). Shut off power and exchange the phase connection if the direction is wrong.
2. Fill the reservoir with hydraulic oil. In consideration of hydraulic power unit's durability and keep the equipment running in the perfect condition, **please use Hydraulic Oil 46#**.
3. Synchronous adjustment (**Lowing down the lift at the lowest position**)
  - a. Turning the handles of shutoff valves to the position as **Fig.30**. Push the button **UP**  to fill the cylinders until both platforms just start to lift up, simultaneously push button **DOWN**  and **Pass** for 5 seconds with buzzer sounds, the buzzer rings and the sound of bubbles can be heard. This operation is to exhaust the air from cylinders. Repeat this operation for 2-3 times until no sound of bubbles are heard.
  - b. Quickly click the button **UP**  until the platforms just to be lifted up.
  - c. Turn the handles of shutoff valves to the positions as **Fig.31**. Push the button **UP**  to check if the platform P1 and P2 can lift up synchronously. If not, repeat the step **a** and **b** until the platform P1 and P2 can lift up synchronously.

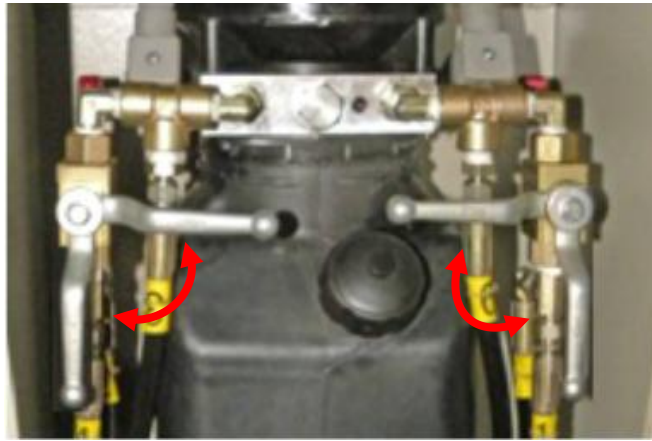


Oil Filling Position  
**Fig. 30**



Normal Working Position  
**Fig.31**

- d. After the platform P1 and P2 were confirmed of acting synchronously, idling test should be done for a complete route of lifting and lowering, and then test with car.
  - e. Once the lift cannot be lowered from the highest position while press **Down**  during idling test , turn the 2pcs shutoff valves quickly into oil filling position (Fig.30), then quickly to normal working position (Fig.31).
- Note: This operation of turning the handles should be finished quickly, non-stop.



## VI. OPERATION INSTRUCTIONS

### To lift vehicle

1. Keep clean of site near the lift, and down the lift to the lowest position;
2. Drive vehicle to the platform and put on the brake;
3. Turn on the power and push the button **UP**, raise the lift to the working position;  
**Note: make sure the vehicle is steady when the lift is raised**
4. Make sure the platforms are in the same level before working then turn off the power switch

### To lower vehicle

1. Clearing the obstacles around or under the lift, and make sure no people around under the lift.
2. Turn on the power switch, push the down button **Down** to lower the lift, the lift is lowered continually and stopped at the height 300mm from ground. Keep feet clear off lift, push button **DOWN** while push the **Lowering Alarm Button(black)** at the side of control cabinet, the lift will be lowered to ground with alarm tone;
3. Driving away the car.
4. Turn off the power switch.

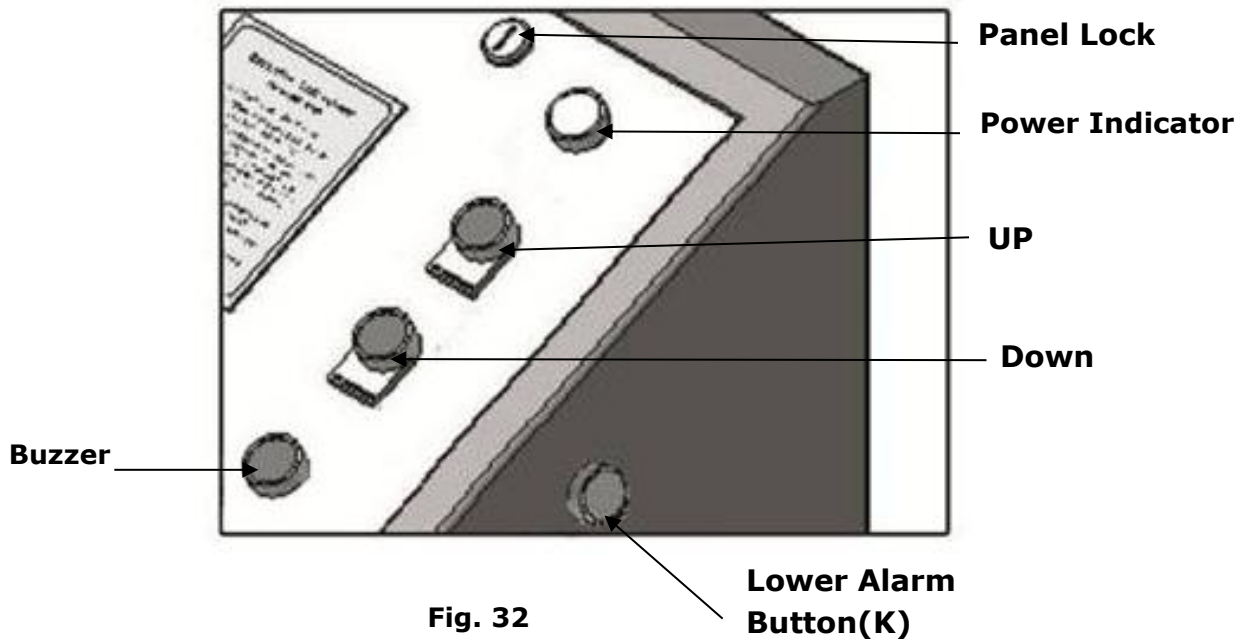


Fig. 32

## VII. MAINTENANCE SCHEDULE

### Monthly:

1. Re-torque the anchor bolts to 150Nm.
2. Lubricate all moving parts with lubricant.
3. Check all fittings, bolts and pins to insure proper mounting.
4. Make a visual inspection of all hydraulic hoses for possible wear or leakage.
5. Adjusting the lifting level on both platforms.

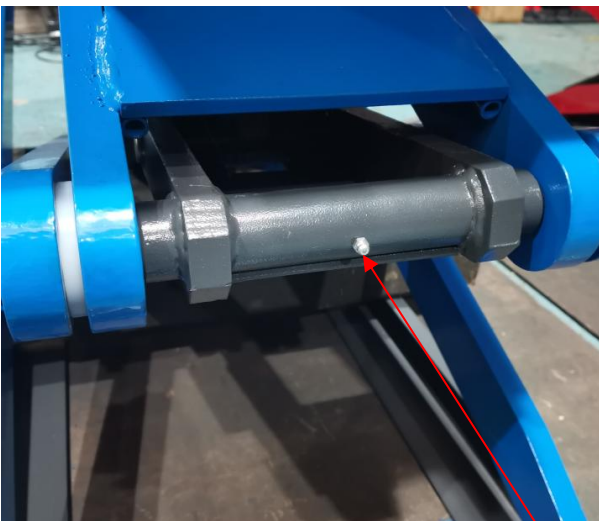


Fig. 33

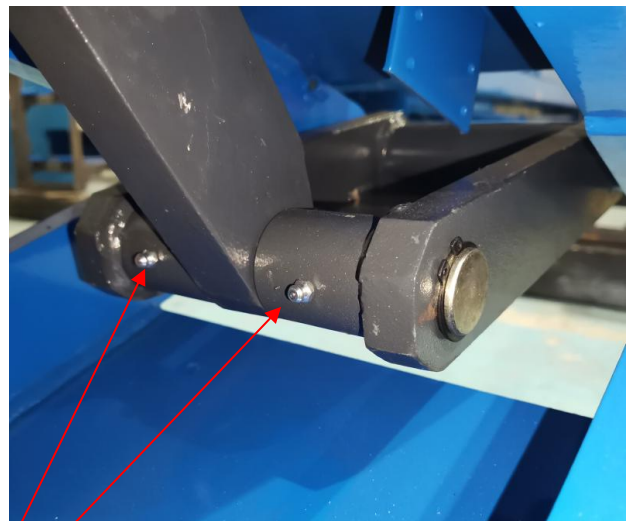
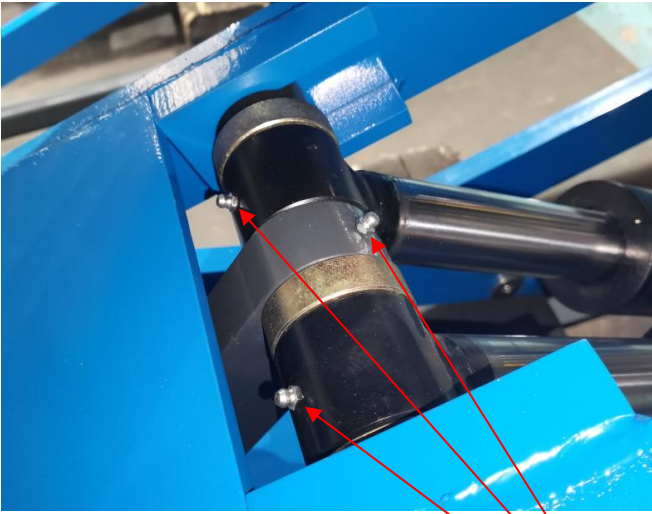


Fig. 34

Greasing



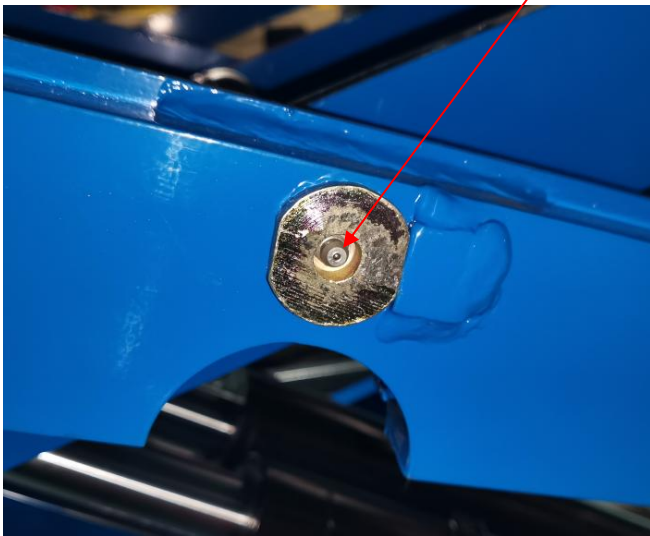


**Fig. 35**



**Fig. 36**

Greasing



**Fig. 37**



**Fig. 38**

**Every six months:**

1. Make a visual inspection of all moving parts for possible wear, interference or damage.
2. Check and adjust the platform as necessary to insure level lifting.
3. Check all fastener and re-torque.

**Oil cylinder maintenance:**

In order to extend the service life of the oil cylinder, please operate according to the following requirements.

1. Recommend to use N46 anti-wear hydraulic oil.
2. The hydraulic oil of the lifts should be replaced regularly during using. Replace the hydraulic oil 3 months after the first installation, Replace the hydraulic oil once a year afterwards.
3. Make at least one full trip raising and lowering per day. For exhausting the air from the system, which could effectively avoid the corrosion of the cylinder and damage to the seals caused by presence of air or water in the system.
4. Protect the outer surface of the oil cylinder's piston rod from bumping and scratching, and timely clean up the debris on the oil cylinder dust-ring and the piston rod.

## VIII. TROUBLE SHOOTING

TROUBLE	CAUSE	REMEDY
Motor does not run	<ol style="list-style-type: none"> <li>1. Button does not work</li> <li>2. Wiring connections are not in good condition or disconnection</li> <li>3. AC contactor in damage</li> <li>4. Motor burned out</li> </ol>	<ol style="list-style-type: none"> <li>1. Replace button</li> <li>2. Repair all wiring connection</li> <li>3. Repair or Replace AC contactor</li> <li>4. Repair or replace motor</li> </ol>
Motor have voice but does not run	<ol style="list-style-type: none"> <li>1. Power lack for one phase</li> <li>2. AC contactor does not contact well</li> </ol>	<ol style="list-style-type: none"> <li>1. Check circuit of Power unit</li> <li>2. Replace AC contactor</li> </ol>
Motor runs but the lift is not raised	<ol style="list-style-type: none"> <li>1. Motor runs in reverse rotation</li> <li>2. Low oil level</li> <li>3. The Gear Pump out of operation</li> <li>4. Relief valve or check valve in damage</li> <li>5. Shaft Coupling in damage</li> </ol>	<ol style="list-style-type: none"> <li>1. Reverse two power wire</li> <li>2. Fill tank</li> <li>3. Repair or replace</li> <li>4. Repair or replace</li> <li>5. Replace Shaft Coupling</li> </ol>
Lift raised slowly	<ol style="list-style-type: none"> <li>1. Oil line is jammed</li> <li>2. Gear Pump leaks</li> <li>3. Overload lifting</li> <li>4. Power Voltage low</li> <li>5. Oil mixed with air</li> </ol>	<ol style="list-style-type: none"> <li>1. Clean the oil line</li> <li>2. Replace Pump</li> <li>3. Check load</li> <li>4. Check electrical system</li> <li>5. Fill tank and bleeding air</li> </ol>
Lift cannot lower	Hydraulic Solenoid valve out of operation	Repair or replace

## IX . Lift disposal.

When the car lift cannot meet the requirements for normal use and needs to be disposed, it should follow local laws and regulations.



## **PEAK CORPORATION**

No. 3 Luomu Road, Shishan Town, Nanhai District, Foshan(528225), Guangdong, China

Tel: 86-757-81102815 81102805

Fax: 86-757-81102809

Email: [peak@peaklift.cn](mailto:peak@peaklift.cn)      <http://www.peaklift.cn>

Manual Part No.: 72216209

Revision Date: 2022/02