

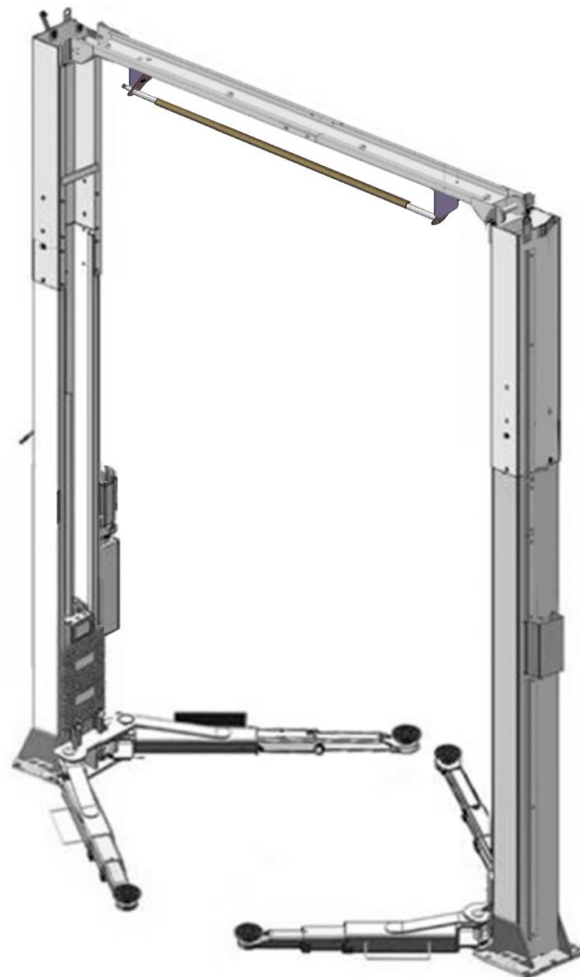

Original

Installation And Service Manual



TWO POST LIFT

Model:209C/209CH

CONTENTS

Product features and specifications.....	1
Installation requirement.....	3
Steps of installation.....	5
Exploded view.....	26
Test run.....	35
Operation Instruction.....	36
Maintenance.....	37
Trouble shooting.....	38
LIFT DISPOSAL	38

I. PRODUCT FEATURES AND SPECIFICATIONS

CLEAR-FLOOR DIRECT-DRIVED MODEL FEATURES

Model 209C 209CH (See Fig. 1)

- Direct-driven design, minimize the lift wear parts and breakdown ratio
- Dual hydraulic cylinders: each cylinder is subjected to high pressure test, high quality seal ring.
- Self- lubricating UHMW Polyethylene sliders and bronze bush
- Single-point safety release, and dual safety design
- Clear-floor design, provide unobstructed floor use
- Overhead safety shut-off device prevents vehicle damage
- 4pcs of 3-stages arms with drop in rubber pads
- Standard adjustable heights accommodates varying ceiling heights

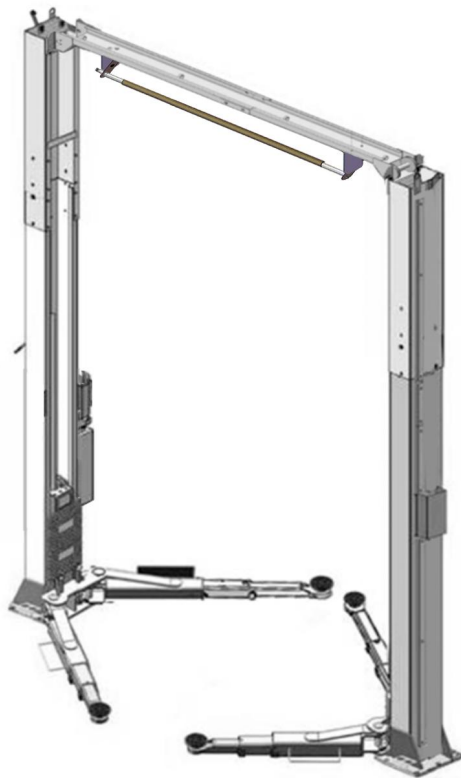

Fig. 1

MODEL 209C 209CH SPECIFICATIONS

Model	Lifting Capacity	Lifting Height	Lifting Time	Overall Height	Overall Width	Minimum Pad Height	Motor
209C	4000KG	1815~2044mm	57s	3621/3821mm	3428mm	90~319mm	2.0/3.0HP
209CH	4000KG	1815~2044mm	57s	4231/4431mm	3428mm	90~319mm	2.0/3.0HP

**Arm Swings View
For Model 209C 209CH**

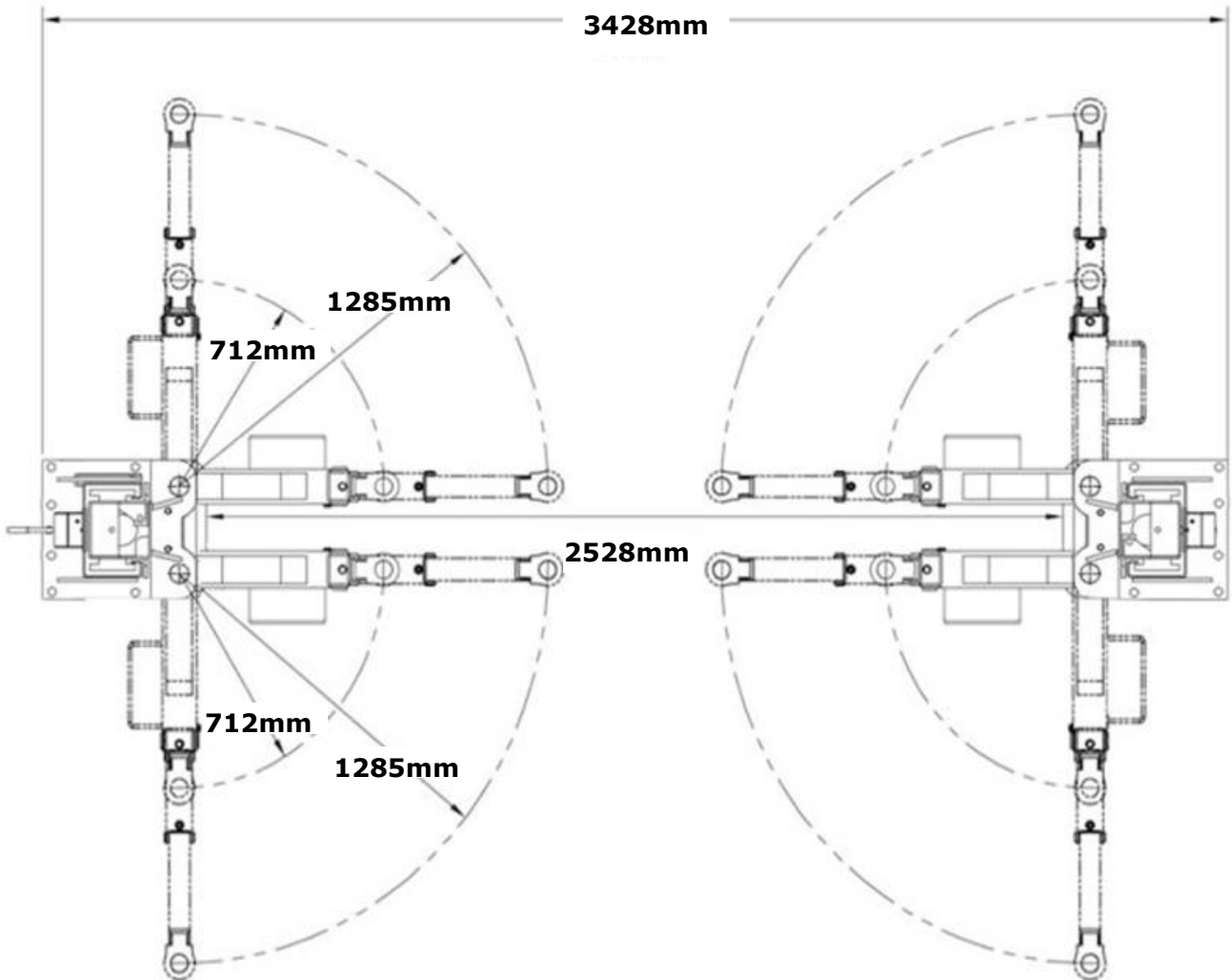

Fig.2

II. INSTALLATION REQUIREMENT

✓ Rotary Hammer Drill ($\Phi 19$)



✓ Hammer



✓ Level Bar



✓ ✓ Spanner (12")



✓ Wrench : (8", 10", 13", 14",
17", 19", 24")



✓ Ratchet Spanner With Socket: (28")



✓ Carpenter's Chalk



✓ Screw srtts



✓ Tape Measure (7.5m)



✓ Pliers



✓ Lock Wrench



✓ Socket Head Wrench : (3", 5", 8")



Fig.3

B. Equipment storage and installation requirements.

The equipment should be stored or installed in a shady, normal temperature, ventilated and dry place.

C. The equipment should be unload and transfer by forklift.



Fig. 4

D. SPECIFICATIONS OF CONCRETE (See Fig. 5)

Specifications of concrete must be adhered to the specification as following.

Failure to do so may result in lift and/or vehicle falling.

1. Concrete must be thickness 100mm minimum and without reinforcing steel bars, and must be dried completely before lift installation.
2. Concrete must be in good condition and must be of test strength 210kg/cm² (3,000psi) minimum.
3. Floors must be level and no cracks.

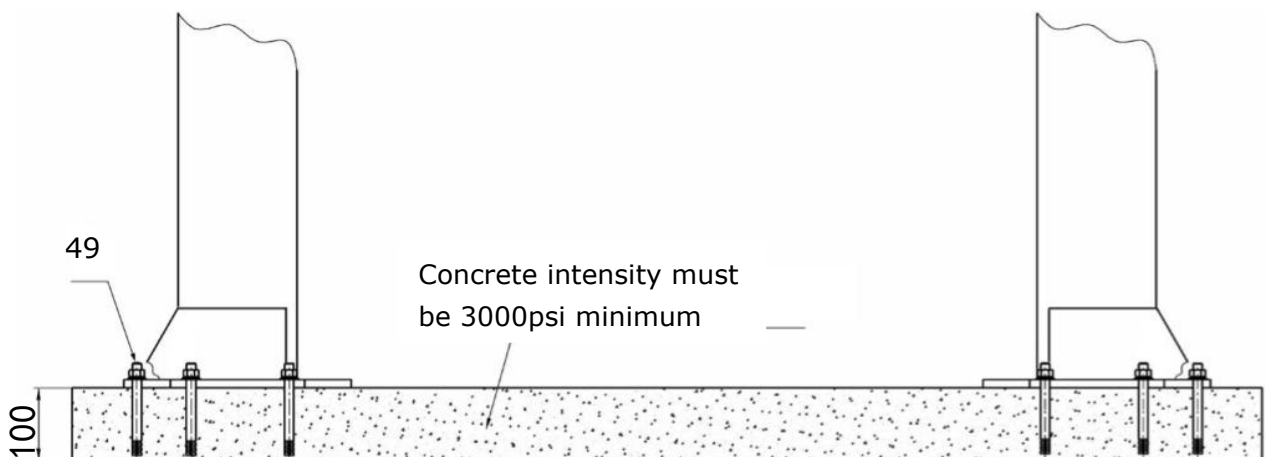

Fig. 5

E. POWER SUPPLY

The electrical source must be 3HP minimum. The source cable size must be 2.5mm² minimum and in good condition of contacting with floor.

III. STEPS OF INSTALLATION

A. Location of Installation

Check and insure the installation location (concrete, layout, space size etc.) is suitable for lift installation.

B. Use a carpenter's chalk line to establish installation layout of base-plate (See Fig.6).

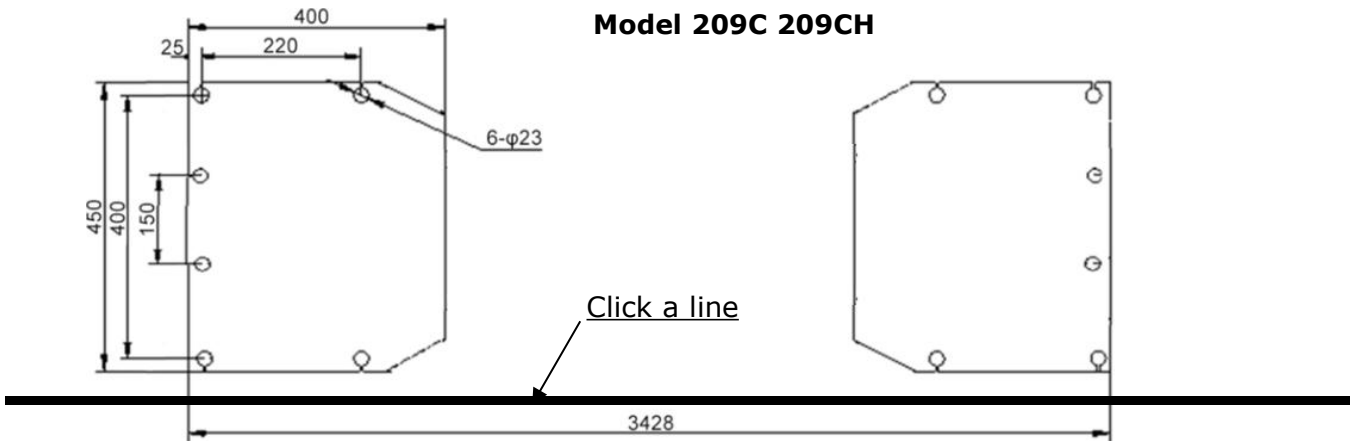

Fig. 6

C. Check the parts before assembly.

1. Packaged lift and hydraulic power unit (See Fig. 7).



Fig. 7

2. Move aside the lift with fork lift or hoist, and open the extension packing carefully , take off the lifting arms and parts box from upper and inside the column, then move them to location nearby installation site, check the parts according to the shipment parts list (See Fig.8).

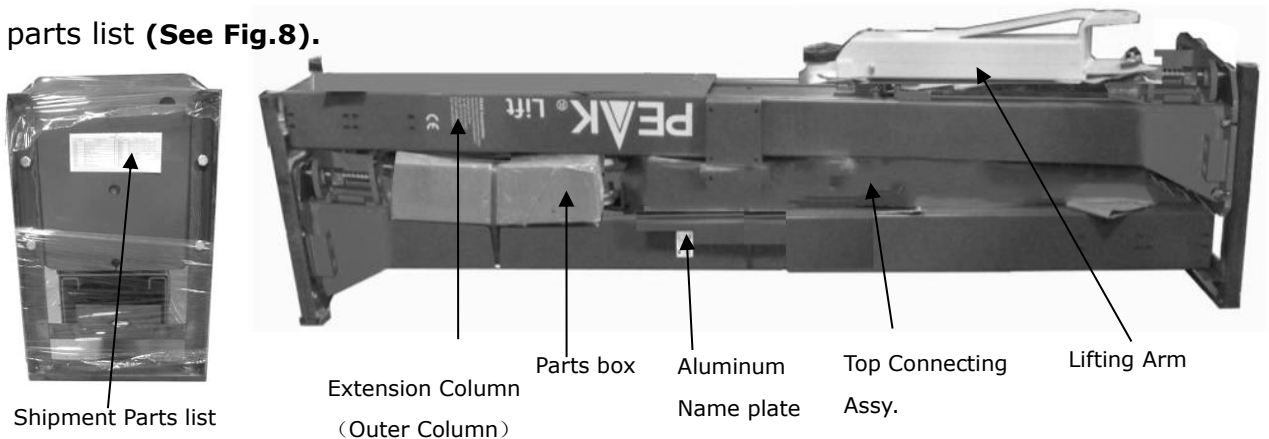

Fig. 8

3. Loosen the screws of the upper package stand, take off the upper extension columns, take out the parts in the inner column and remove the package stand
4. Move aside the parts and check the parts according to the shipment parts list
(See Fig.9, 10).

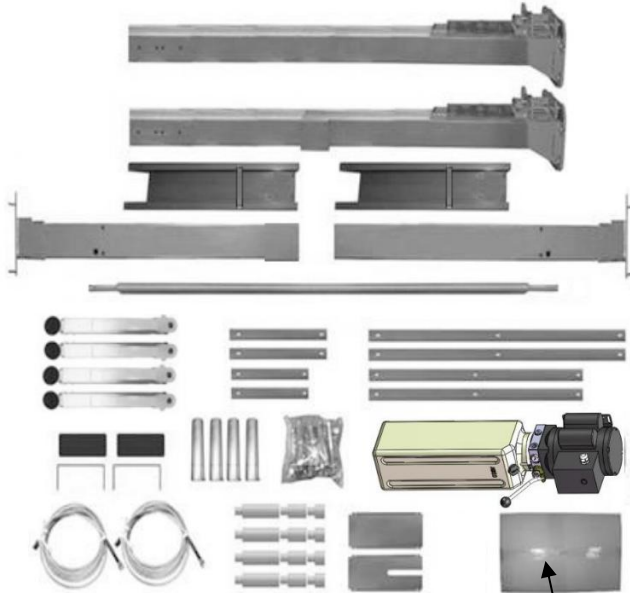

Fig. 9
Parts for 209C,209CH in the shipment parts list 50



Fig. 10
Parts in the parts box 50)

5. Open the bag 1 of parts and check the parts according to parts box list (See Fig. 11).

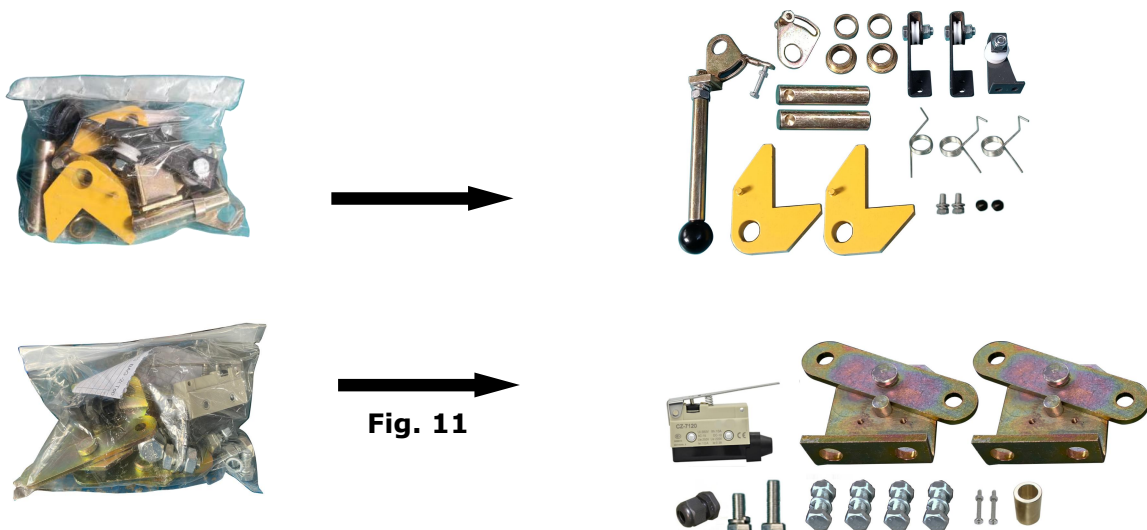

Fig. 11

6. Open the bag 2 of parts and check the parts according to parts bag list (See Fig. 12).

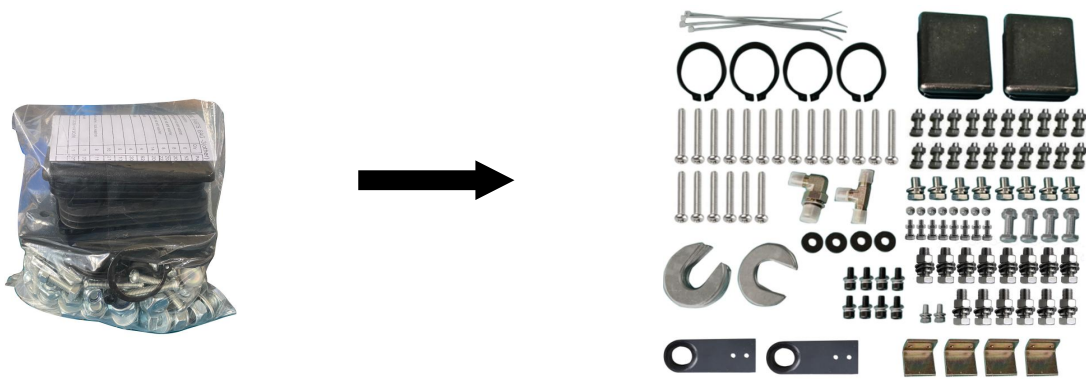

Fig. 12

D. Install parts of extension columns (See Fig. 13).

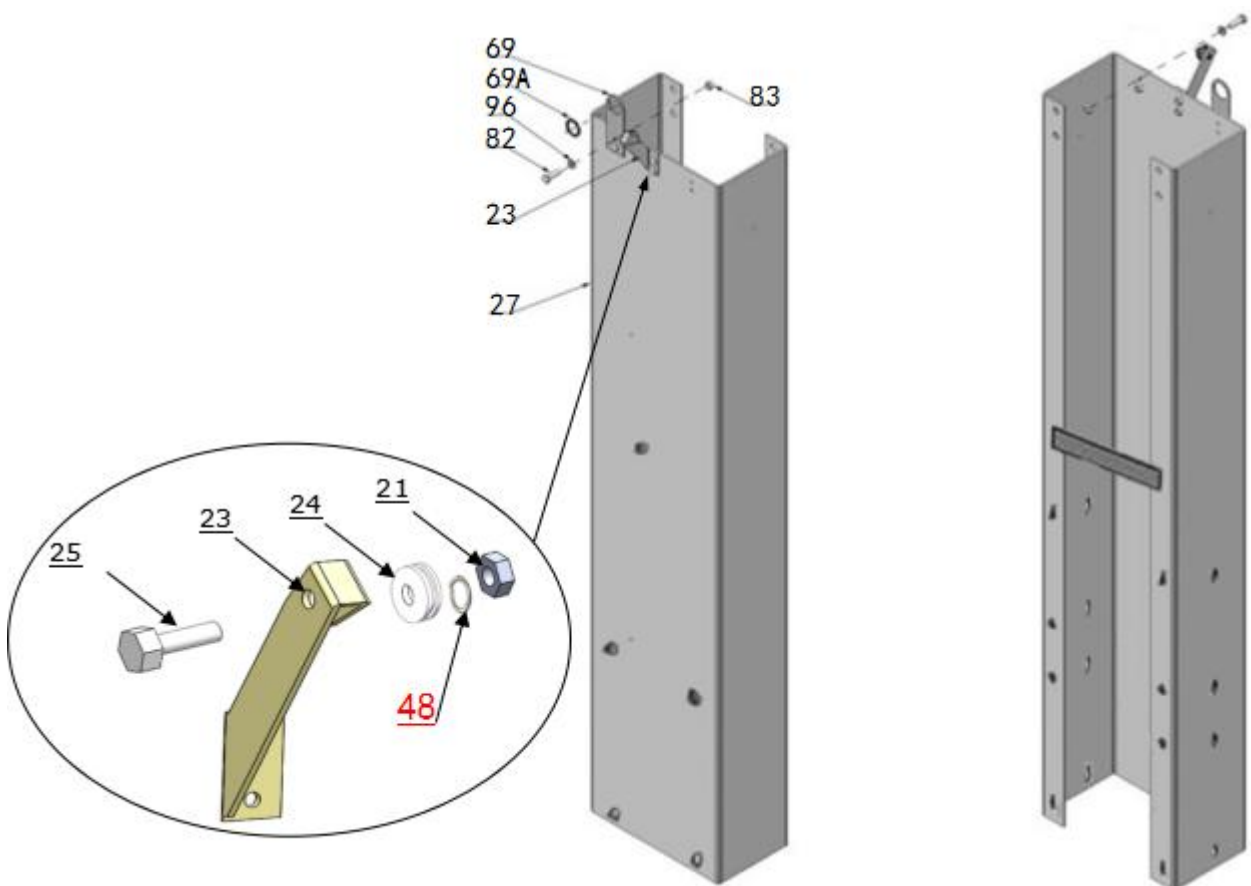

Fig. 13

E. Position power-side column

Lay down two columns on the installation site parallelly, position the power-side column according to the actual installation site. Usually, it is suggested to install power-side column on the front-right side from which vehicles are driven to the lift. This lift is designed with 2-Section columns. Adjustable height according to the ceiling height and connecting the inner and extensions columns.

1. 209C requirement: Ceiling height over 3850mm, can be both low setting/high setting, Ceiling height between 3650-3850mm, only available low setting. Ceiling height less than 3650mm not available this model.
2. 209CH requirement: Ceiling height over 4460mm, can be both low setting/high setting, Ceiling height between 4260-4460mm, only available low setting. Ceiling height less than 4260mm not available this model.

Note:

- a. For high setting, connect the lower hole of the extension columns (See Fig.14).
- B. For low setting, connect the upper hole of the extension columns (See Fig.15).

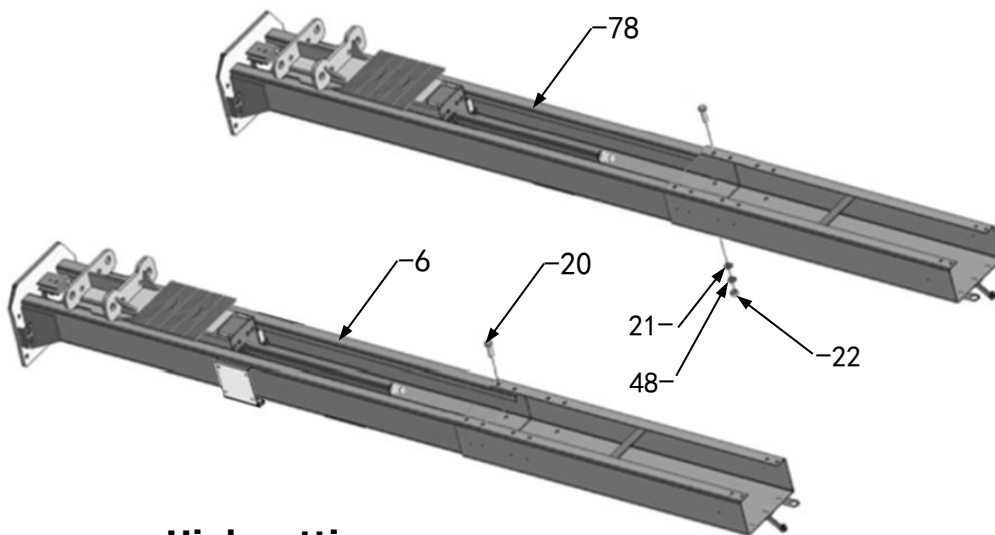

**High setting
Fig 14**

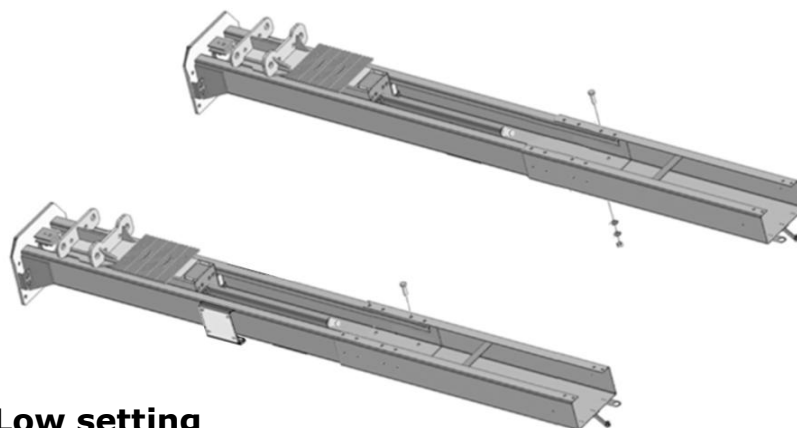

**Low setting
Fig 15**

F. Position columns (See Fig. 16)

Position the columns on the installation layout of base-plate, Install the anchor bolts. Check the Columns plumpness with level bar, and adjusting with the shims if the columns are not vertical. Do not tighten the Anchor Bolts.

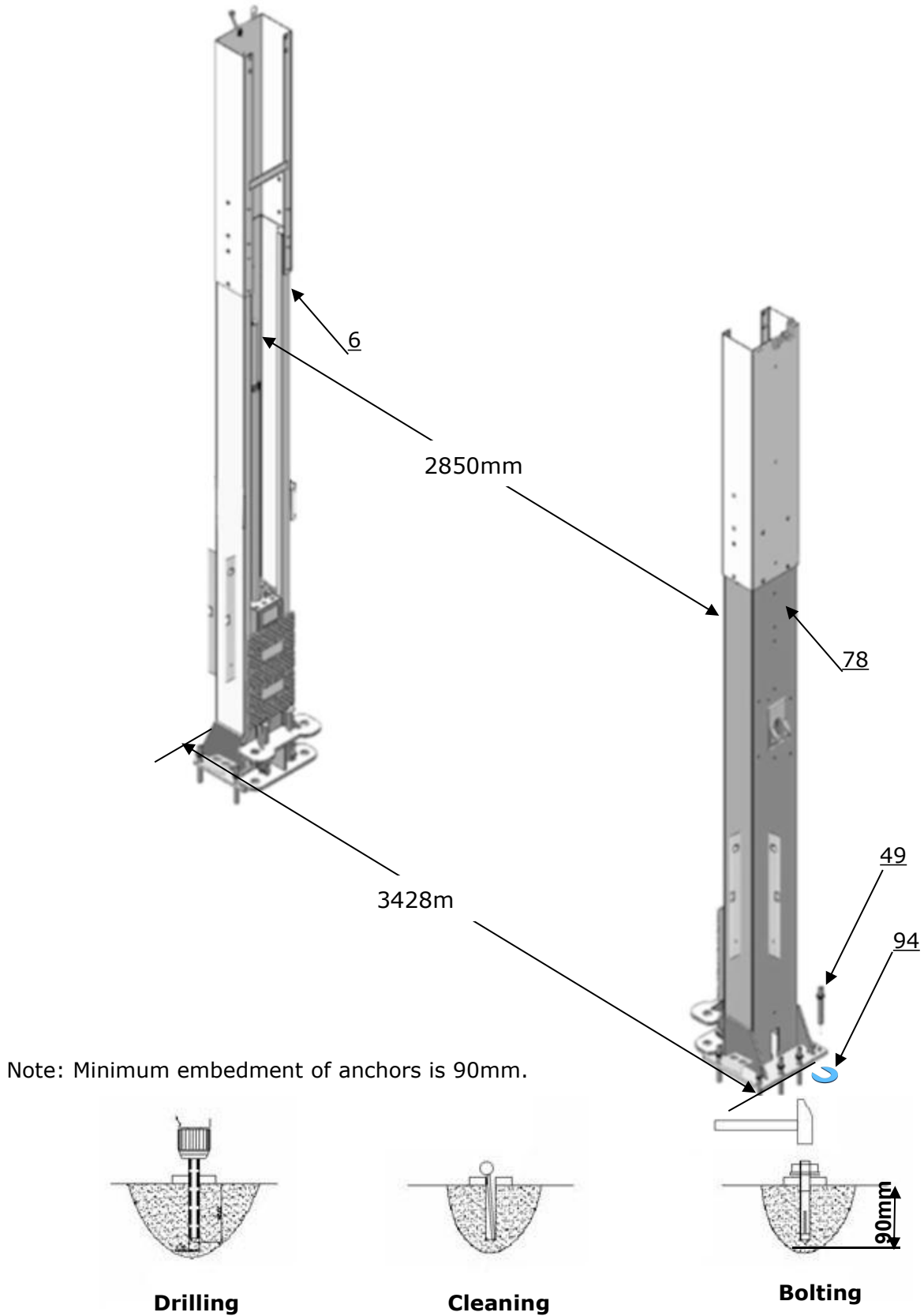

Fig. 16

G. Install overhead top beam

1. With help of the hook of top beam, put one side of top beam on top of the extension column and connecting the top beam to extension column by bolts, tighten the bolts. Then assemble the connecting bracket (**See Fig. 17**).



Fig. 17

2. Assemble overhead top beam, tighten the columns anchor bolts (See Fig. 18).

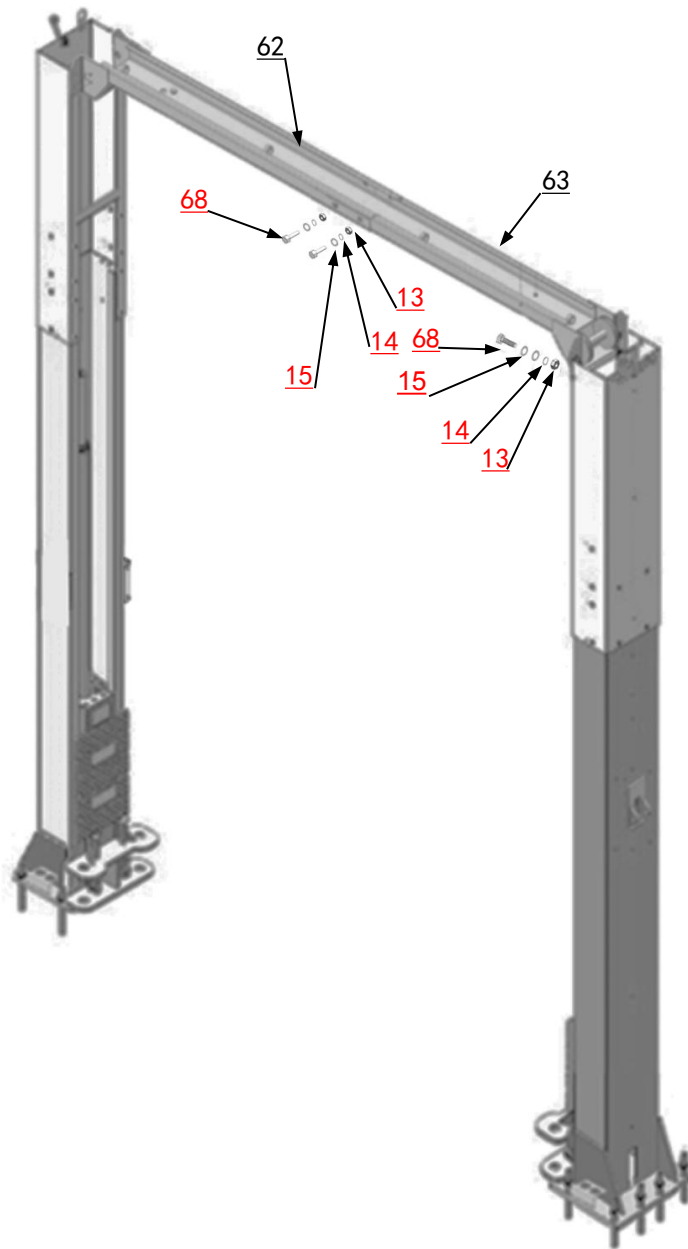
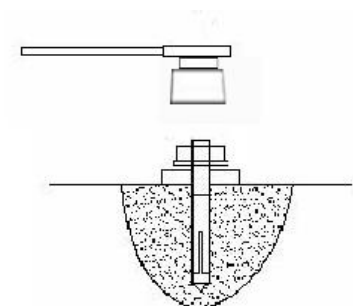

Fig. 18



Tighten the anchor bolts with ratchet spanner with socket

Note: Torque of Anchors is 150N.m.

H. Install control bar for limit switch (See Fig.19)

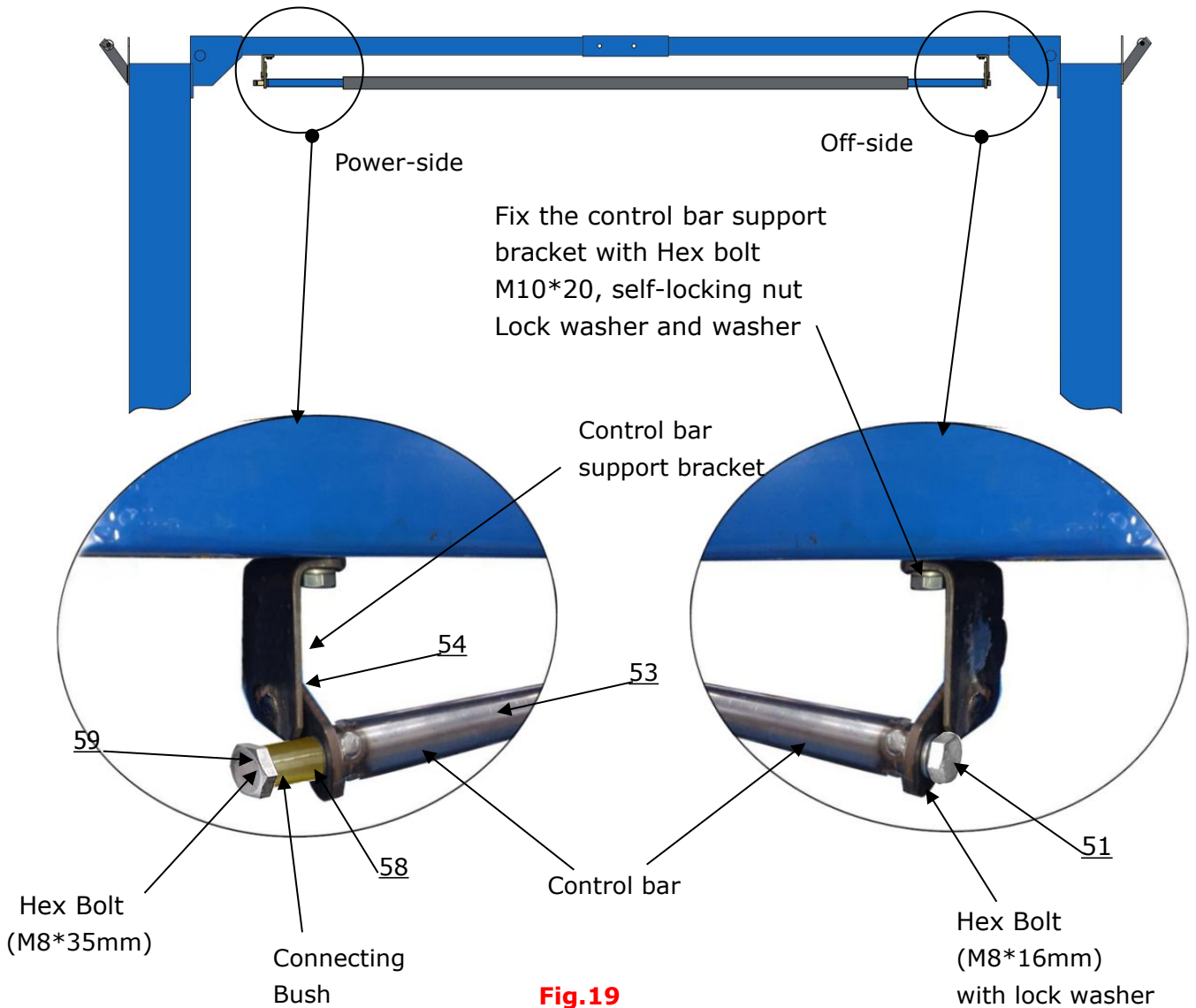

I. Installing the limit switch and wire.

1. Connect the wire:

Connect the red wire to terminal NC#, another side of the wire connect to the terminal A2 on AC contactor of power unit.

Connect the black wire to terminal C#, another side of the wire connect to the terminal 4 on control button of power unit.

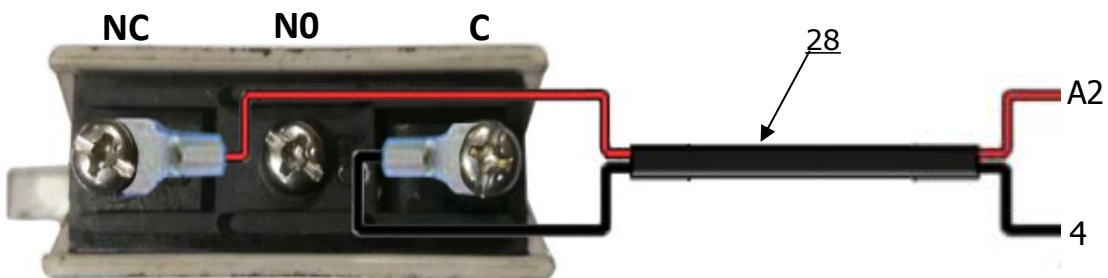

2. Tighten limit switch .Fix the limit switch on control bar support bracket of the power-side as the photo. The wire pass through the top beam and connected to the AC contactor of power unit.

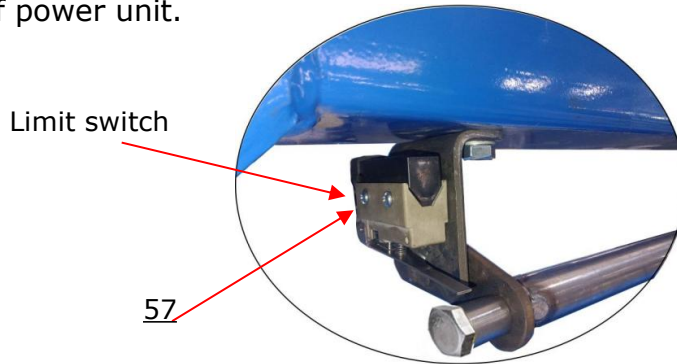

Fig. 21

J. Install safety device (See Fig. 22 & Fig. 23).

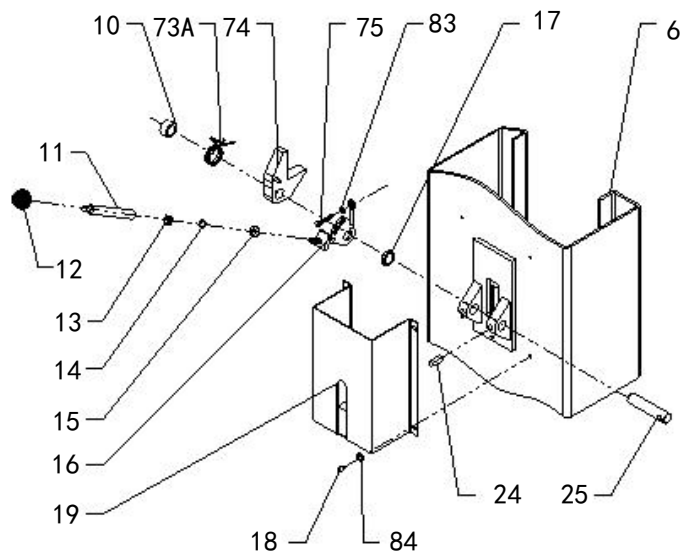

Fig. 22 Power-side Safety Device

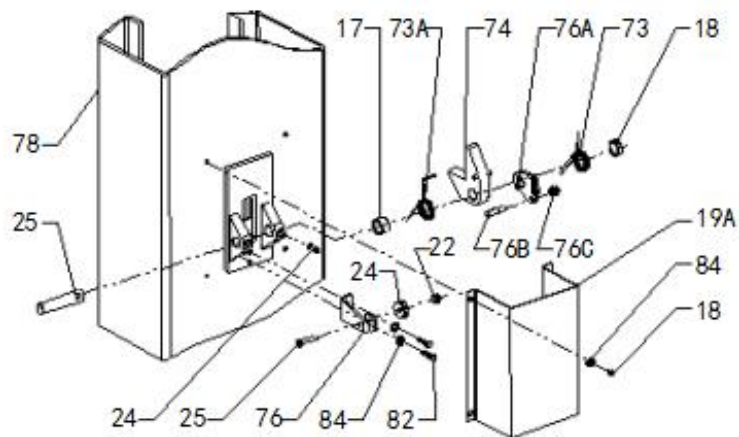

Fig. 23 Offside Safety Device

K. Install cables

Lift the carriages up by hand and make them be locked at the same level

1. Low setting cable connection (See Fig. 24).

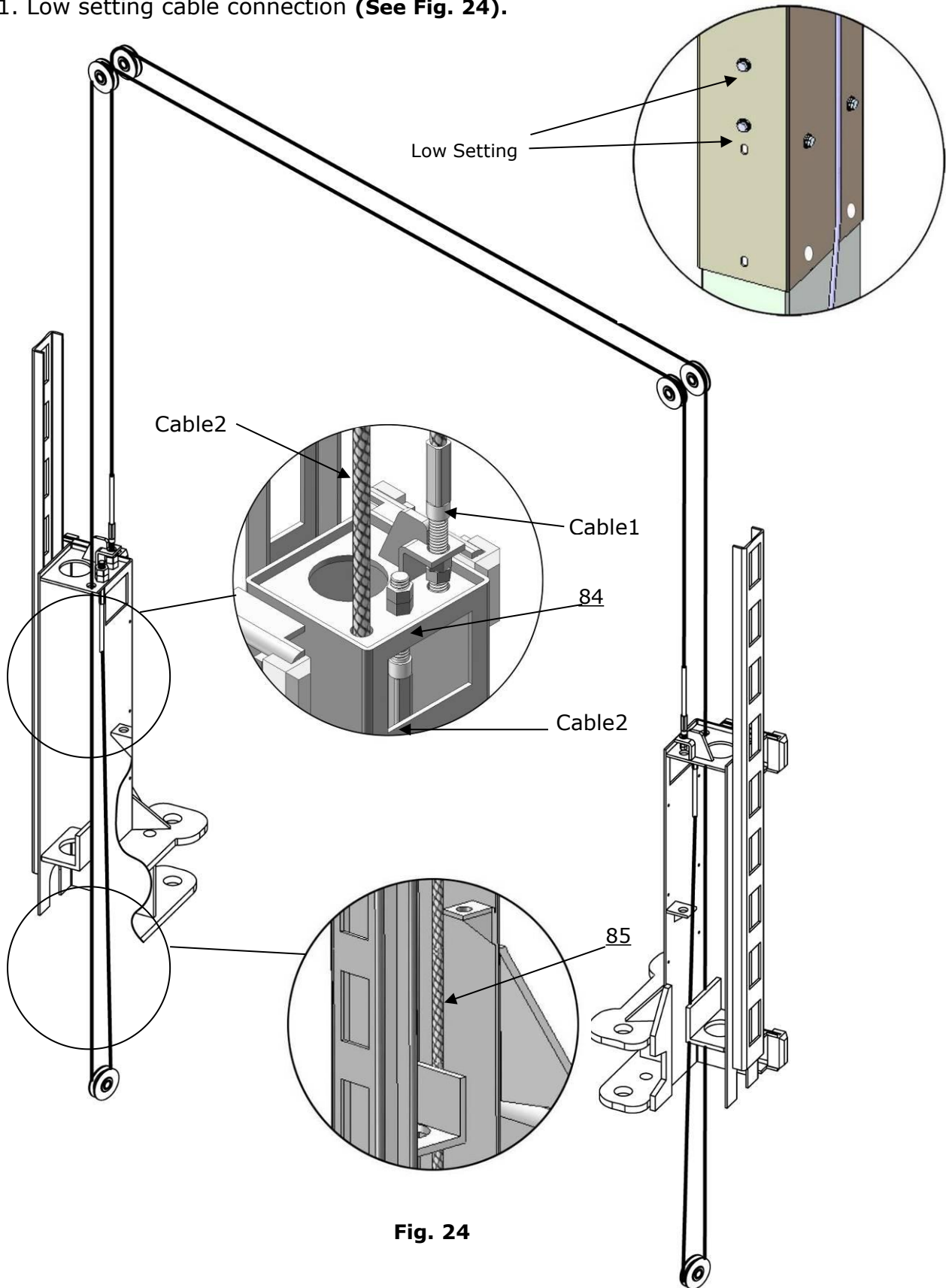

Fig. 24

2. High setting cable connection

2.1. Cable cross over from the bottom of the carriages and be pulled out from the open of carriages, then screw the two cable nuts (See Fig. 25).

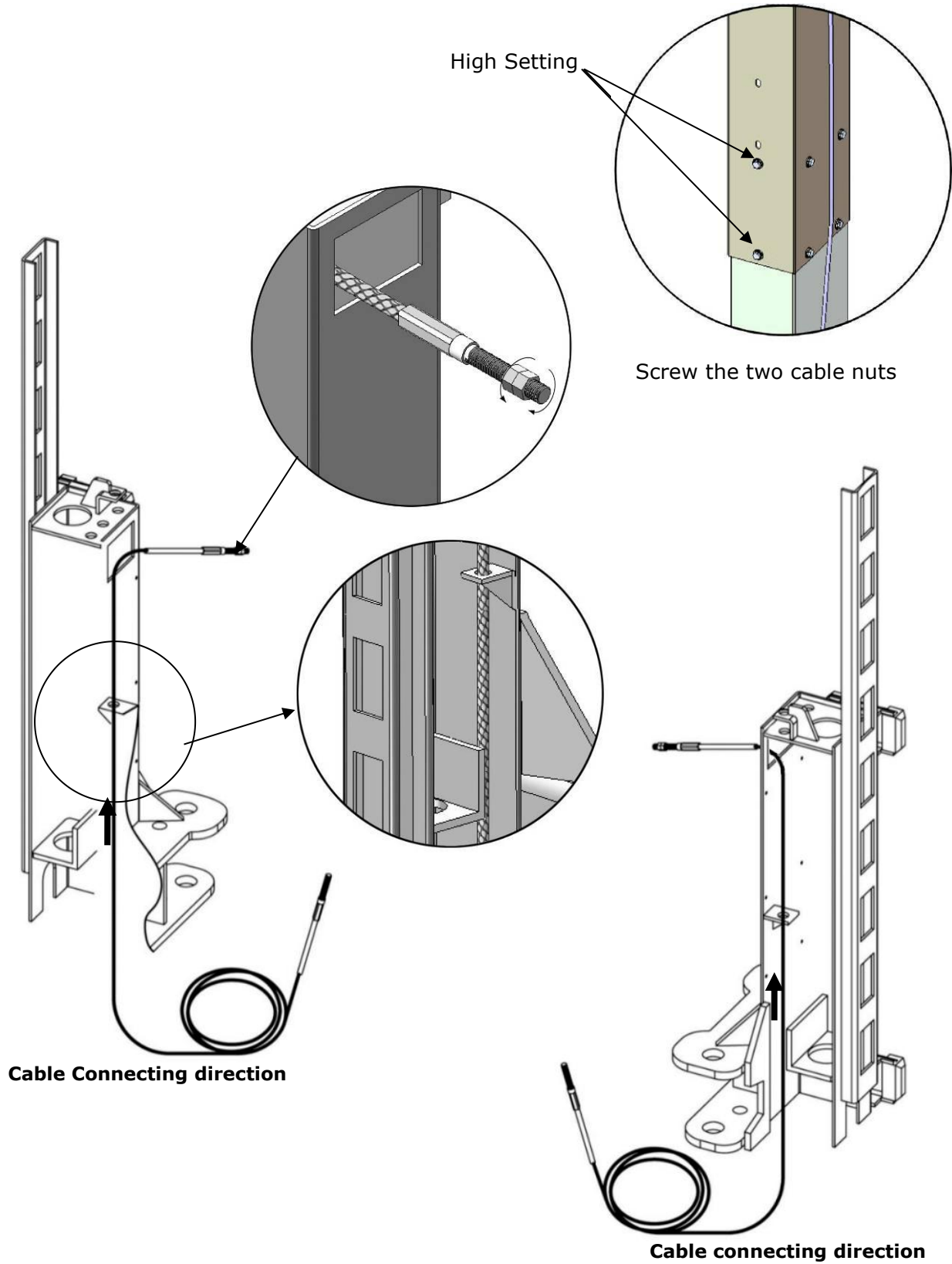

Fig. 25

2.2 Connecting cable for high setting (See Fig. 26).

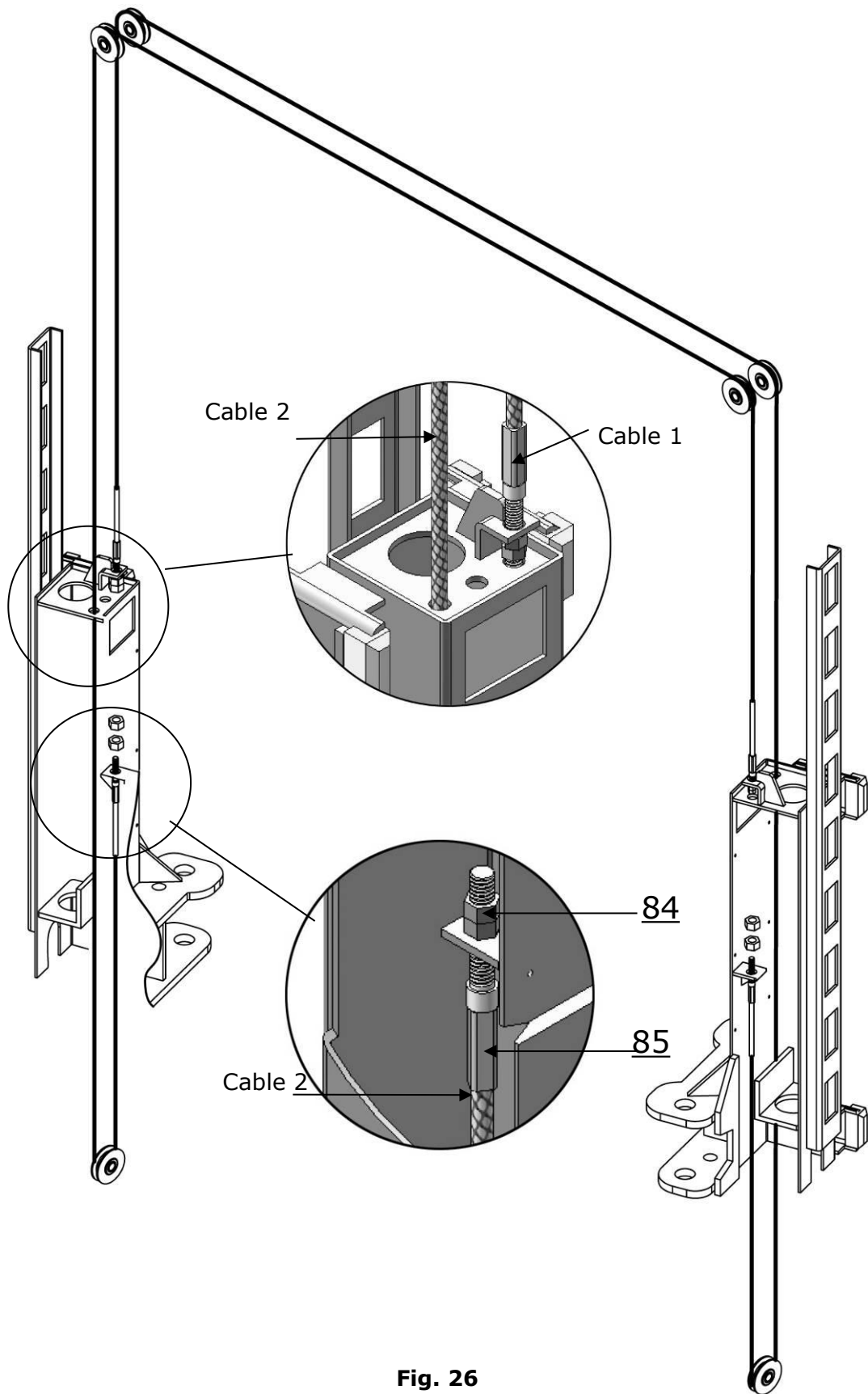

Fig. 26

L. Install hydraulic power unit and oil hose assy.

1. Oil-line connecting drawing. (See Fig.27)

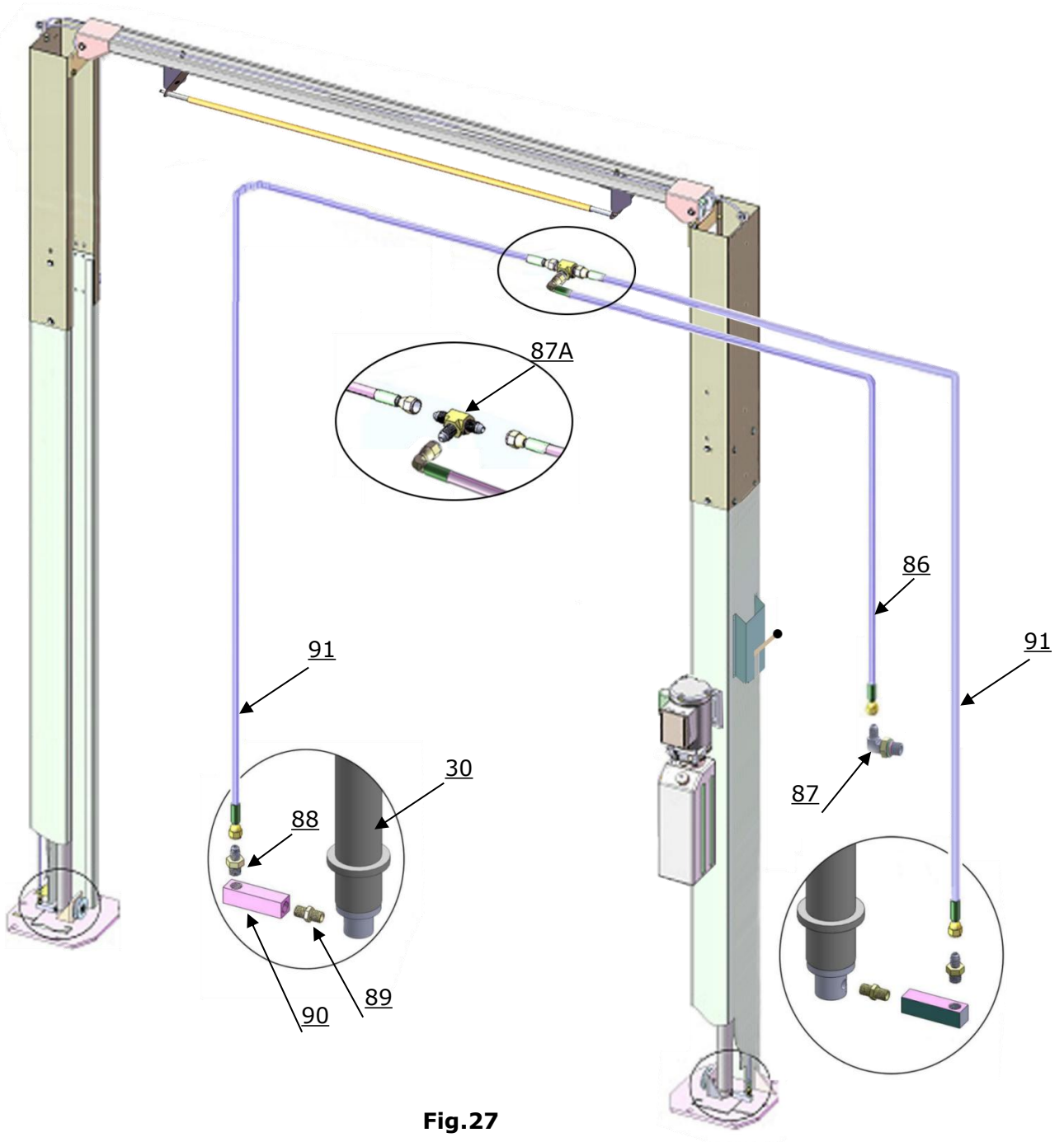

Fig.27

Tighten all the hydraulic fittings, and fill the reservoir with hydraulic oil.

Note: In consideration of Hydraulic Power Unit's durability and keep the equipment running in the perfect condition, please use Hydraulic Oil 46#.

2. Follow these step to connect the oil hose of power unit.

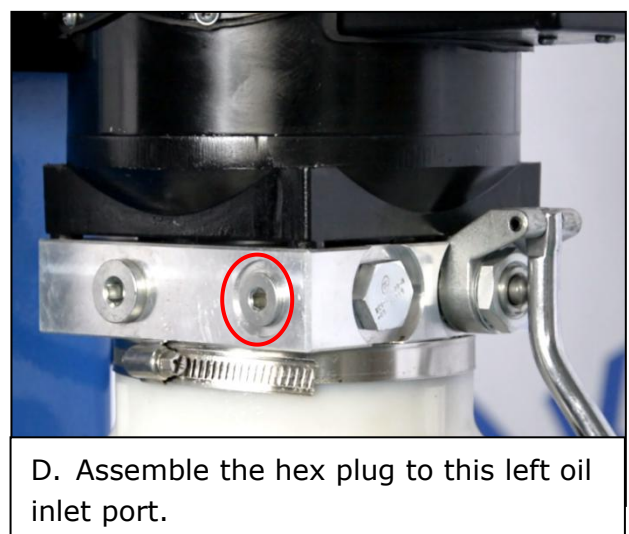
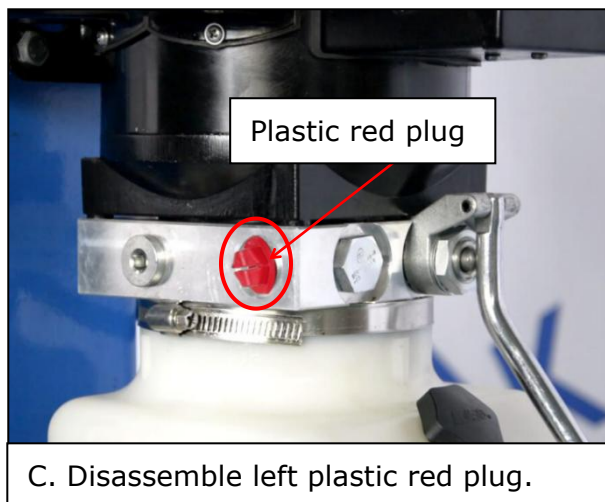
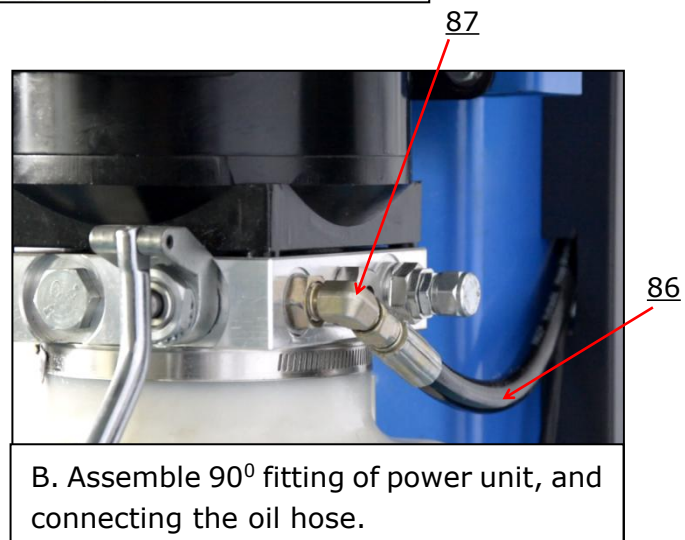
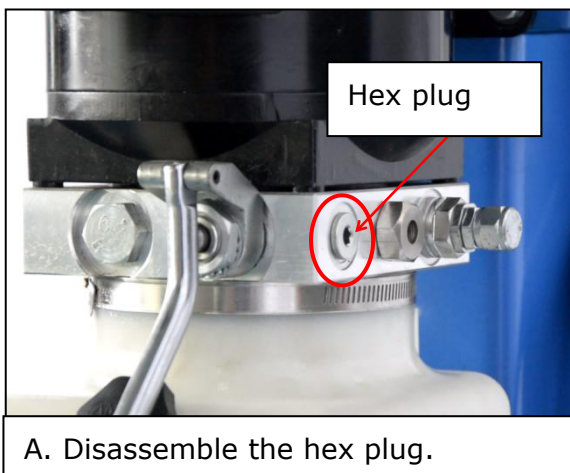
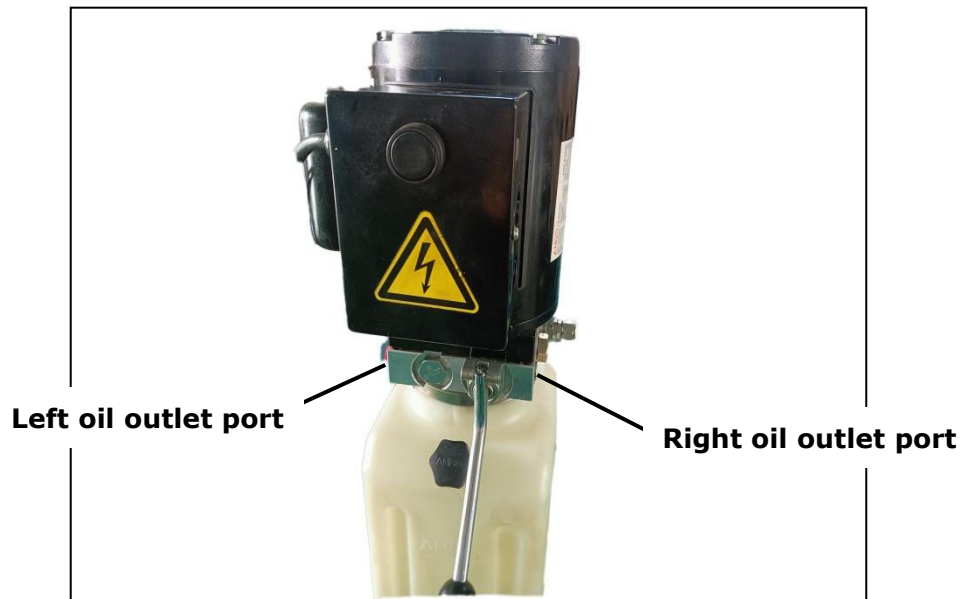

Fig.28

M. Install protective cover Fig.29

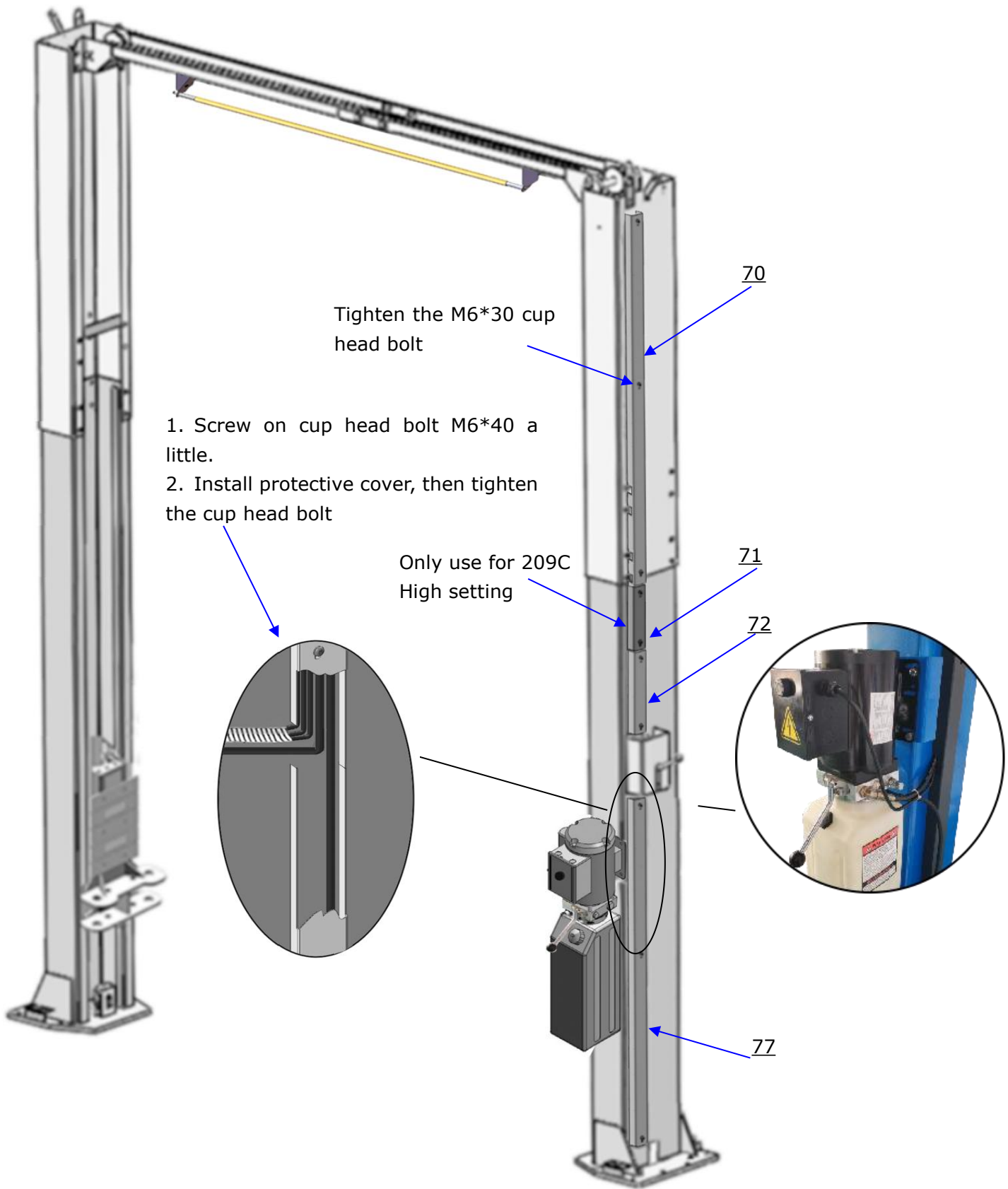

Fig.29

N. Install safety cable (See Fig. 30)

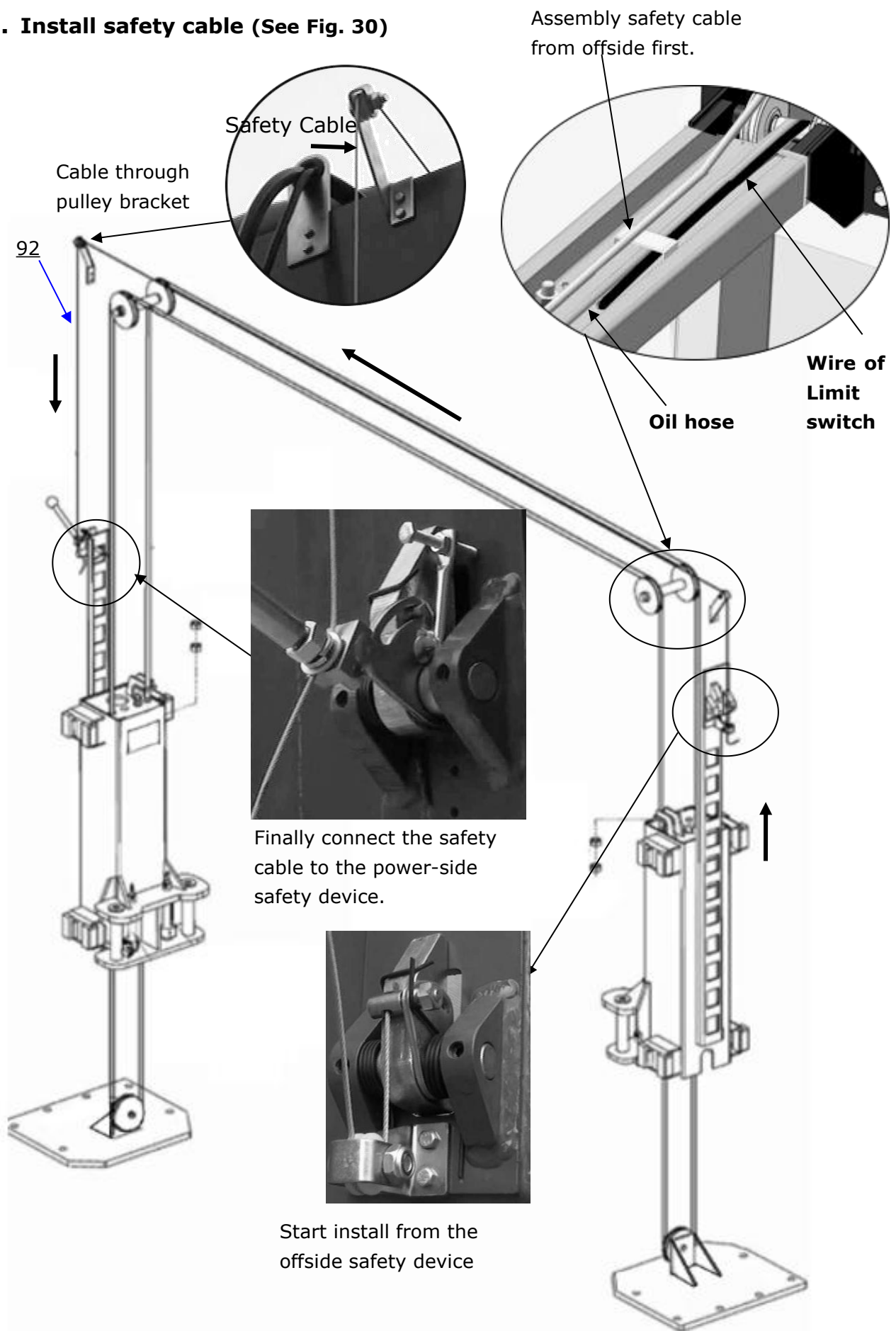
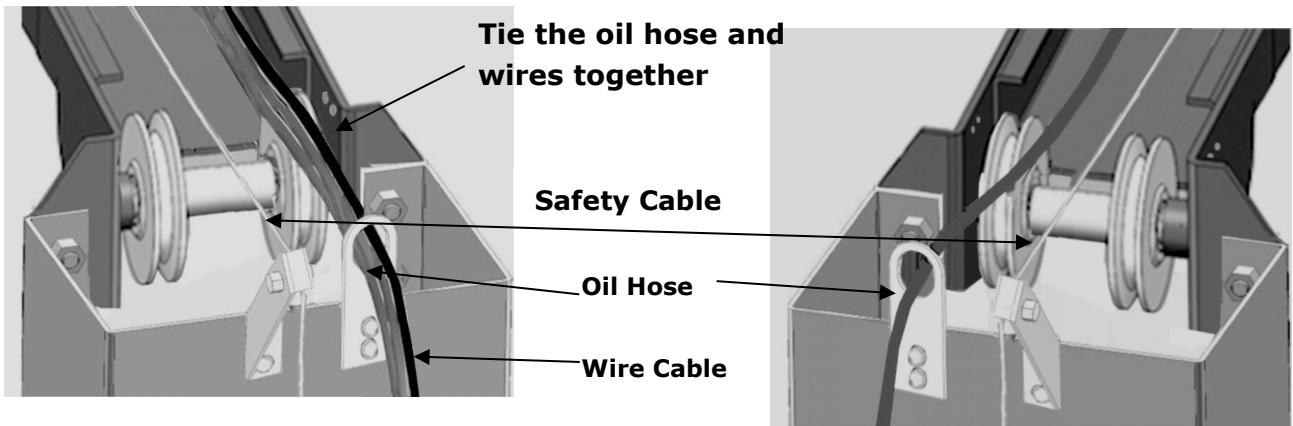

Fig.30

Note: Don't cross the oil hose and safety cable together (See Fig. 31 & Fig.32).



**Power-side Safety Device
Fig. 31**

**Offside Safety Device
Fig.32**

O. Install cable limit bracket.

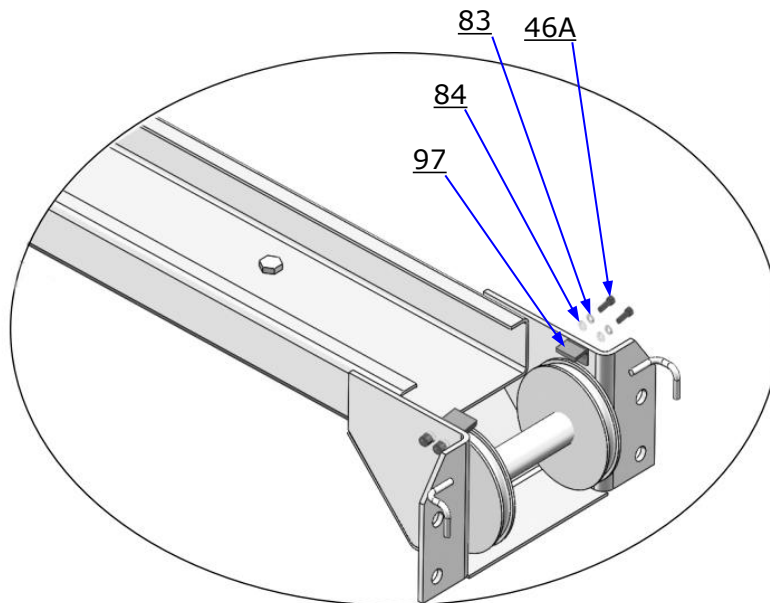

Fig.33

P. Install lifting arms and adjust the arm locks.

1. Install the lifting arms (See Fig. 34).
2. Lowering the carriages down to the lowest position, then use the 8# socket head wrench to loosen the socket bolt (See Fig. 35).

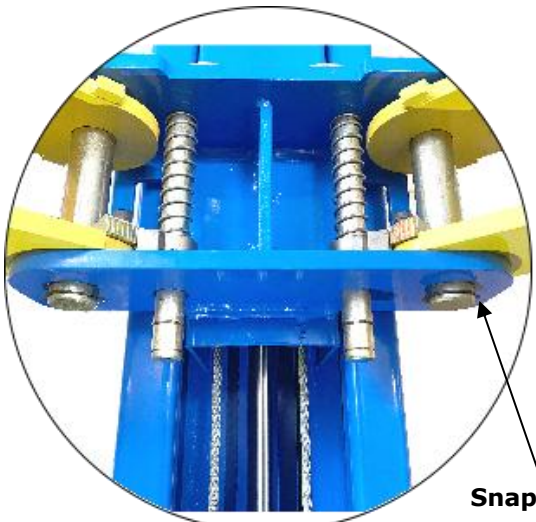

Fig. 34

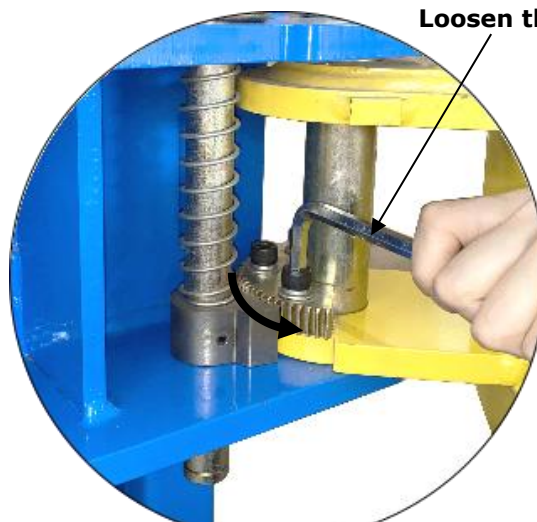

Fig. 35

Use the 8# Socket Head Wrench to loosen the Socket Bolt.

3. Adjust the arm lock as direction of arrow (See Fig. 36)

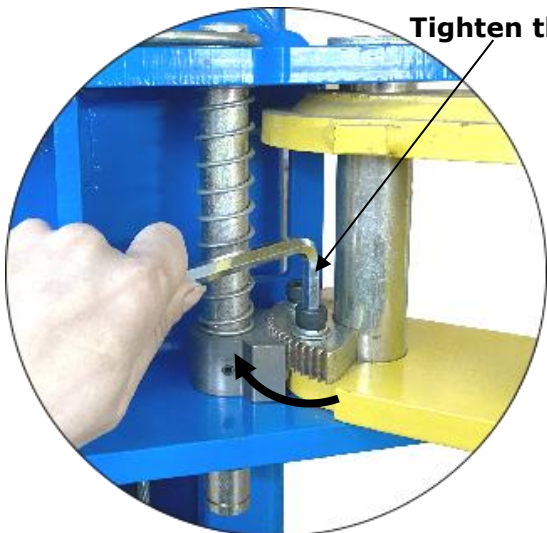

Fig. 36

Locking the bolts after the moon gear and arm lock engaged well.

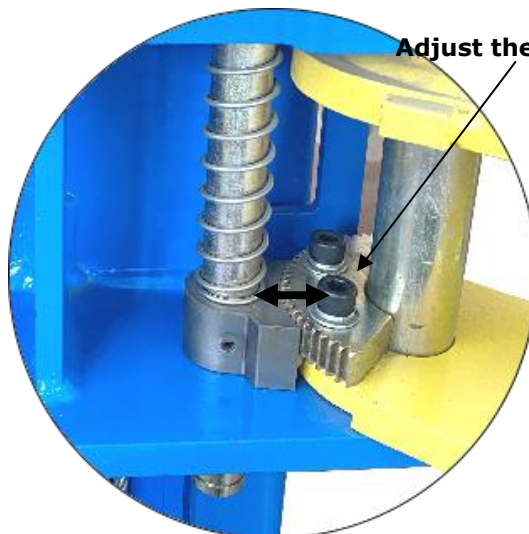

Fig. 37

Adjusting moon gear and arm lock to mesh.

4. Adjust moon gear and arm lock to make it to be meshed, then tighten the socket bolts of arm lock (See Fig.37.)

Q. Tighten all the hydraulic fittings, and fill the reservoir with hydraulic oil.

Note: In consideration of Hydraulic Power Unit's durability and keep the equipment running in the perfect condition, please use Hydraulic Oil 46#.

R. Install electrical system

Connect the power source on the data plate of power unit.

Note: 1. For safety of operators, the power wiring must contact the floor well.

2. Pay attention to the direction of rotations when using three phase motors.

Single phase motor (See Fig.38)

1. Connecting the two power supply lines (fire wire **L** and zero wire **N**) to terminals of AC contactor marked **L1, L3** respectively.
2. Connecting Limit switch: Remove the short wire connecting terminal 4# of control button and A2 of AC contactor firstly (See Fig.38). Then connect wire C#(black wire) of limit switch with terminal 4# of control button and connecting wire NC#(red wire) with terminals A2 of AC contactor respectively. (See Fig. 39)

The interior wire of limit switch connecting NC# and C#, refer to Step I.

Single Phase Circuit diagram

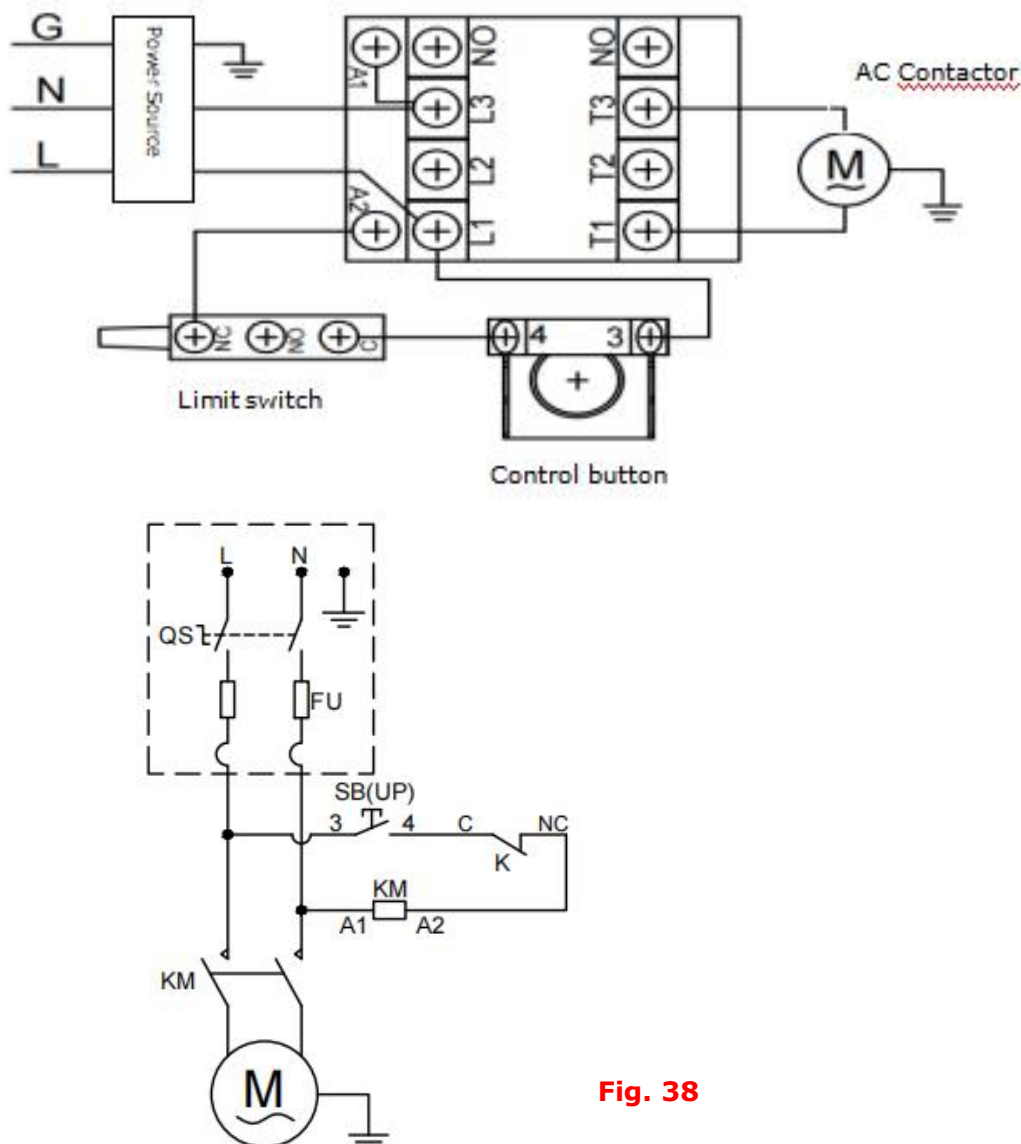

Fig. 38

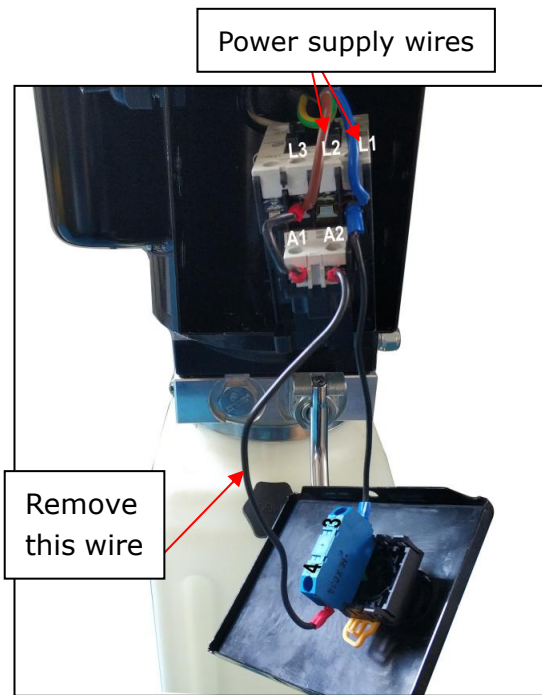

Fig. 39

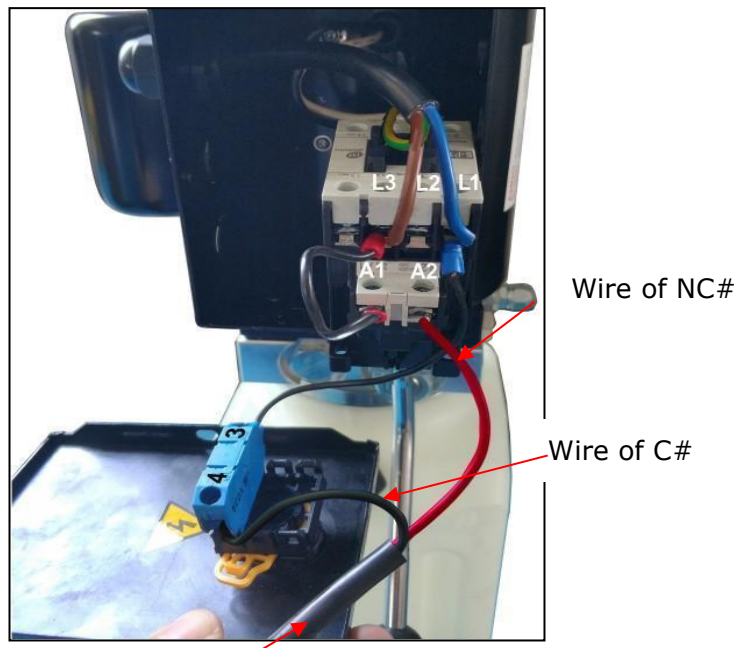

Fig.40

Three phase motor

1. Circuit diagram (See Fig. 41)

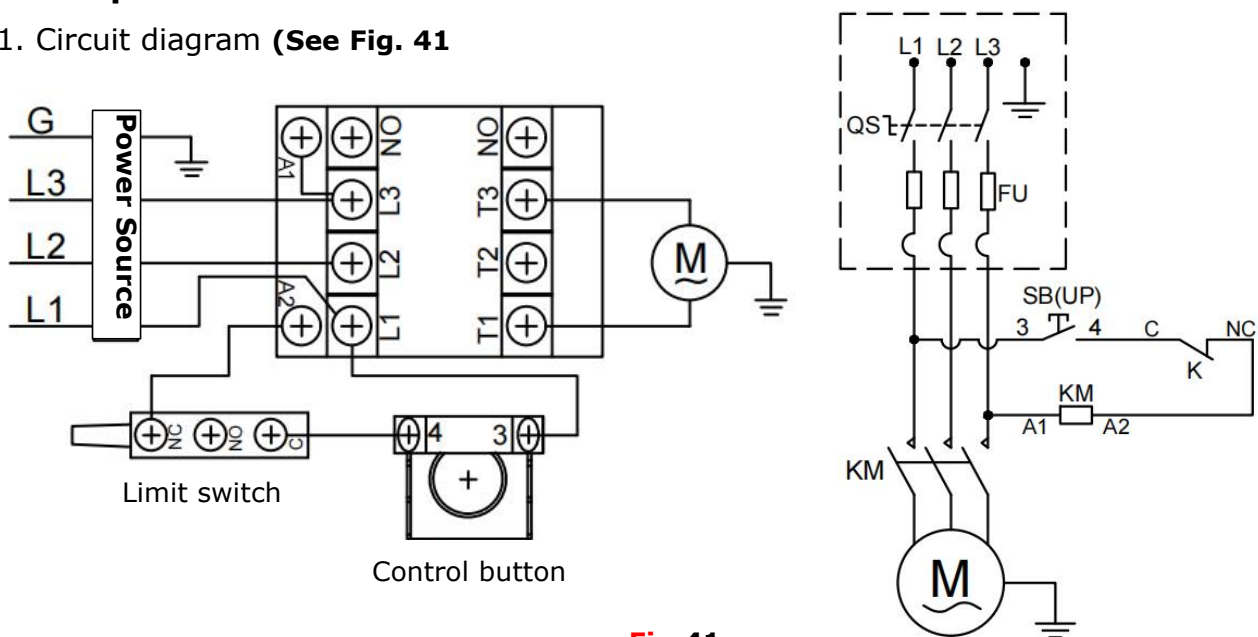

Fig.41

2. Connection step (See Fig.42)

- a. The power supply three fire wires (L1, L2, L3) are connected with terminals of AC contactor marked L1, L2, L3 respectively.
- b. Remove the jumper wire which connect with terminal 4# of switch button and terminal A2# of AC contactor.

- c. Wire of limit switch C#(Black wire) connect to terminal 4# of switch button. Wire NC#(Red wire) connect to terminal A2# of AC contactor.
- d. Terminals 3# of switch button connect with L1 terminals of AC contactor.

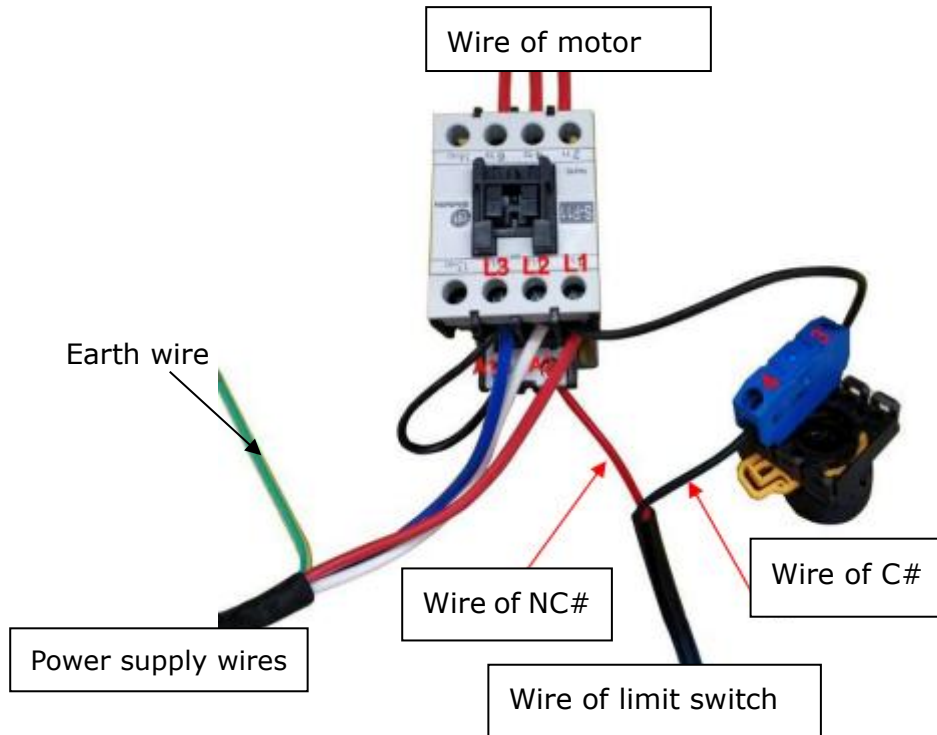

Fig. 42

IV. EXPLODED VIEW

Model 209C 209CH

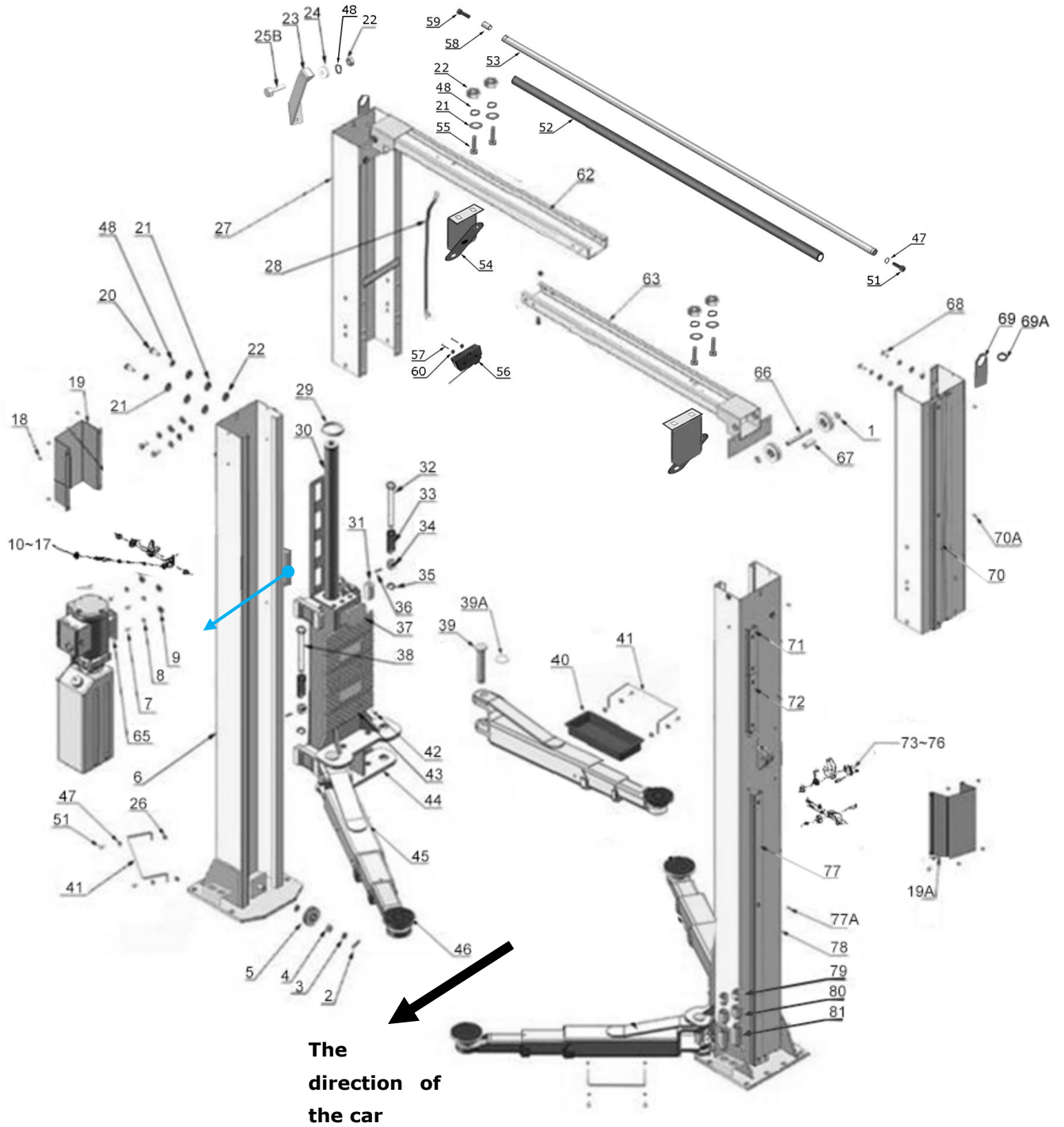

Fig. 43

Parts List

Item	Part#	Description	Qty.		Note
			209C	209C	
1	10206019	Snap Ring ϕ 19	4	4	
2	10209012	Hair Pin ϕ 3.2	2	2	
3	10209128	Washer ϕ 20	4	4	
4	1002011001	Bronzed bush ϕ 22* ϕ 19*14	6	6	
5	1102011001	Pulley ϕ 80* ϕ 22*15	6	6	
6	11206001C	Power Side column	1	1	
7	10209003	Hex Bolt M8*25	8	8	
8	10209004	Rubber Ring ϕ 8*20*3	4	4	
9	10209005	Self Locking Nut (M8)	4	4	
10	11217436	Safety device spacer ϕ 27*15	2	2	
11	11217006	Safety device control handle	1	1	
12	10217005	Plastic ball	1	1	
13	10206023A	Hex Nut	15	15	
14	10420026	Lock Washer ϕ 12	15	15	
15	10206006	Washer ϕ 12	15	15	
16	11217004	Main Cam Lock	1	1	
17	11217012	Safety device spacer	2	2	
18	10209009	Cup head bolt M6*8	10	10	
19	11217405	Power-side safety device cover	1	1	
19A	11217406	Off-side safety device cover	1	1	
20	10209126	Hex Bolt	20	20	
21	10209022	Washer ϕ 10	44	44	
22	10209021	Hex Nut M10	27	27	
23	11217379	Safety Cable Bracket	2	2	
24	10206009	Plastic pulley	3	3	
25	10209046	Hex Bolt M10*35	3	3	
26	10209033	Washer ϕ 8	12	12	
27	11206204	Extension Column L=1240mm	2	0	
	11206207	Extension Column L=1850mm	0	2	
28	10206137	Wire L=3700	1	0	
	10206138	Wire L=4310	0	1	
29	10209111	Cylinder protective Ring	2	2	
30	11217056	Cylinder ϕ 50*1727	2	2	
31	10209015	Slider Block	16	16	
32	11206046A	Arm Lock Bar (Left)	2	2	
33	10206050A	Spring	4	4	
34	10217044-01	Arm Lock	4	4	
35	10206032	Snap Ring	4	4	
36	10206036	Hair Pin	4	4	
37	10209016	Carriage plastic cover	2	2	
38	11206046	Arm Lock Bar (Right)	2	2	
39	11217168	Arm Pin	4	4	

Item	Part#	Description	Qty.		Note
			209C	209C	
39A	10520023	Snap Ring	4	4	
40	10206190	Tool Tray (Short)	2	2	
41	11206191	Short Toe Guard	4	4	
42	10209019	Screw	12	12	
43	10209018	Protective Rubber	2	2	
44	11279004	Carriage	2	2	
45	10203156	Front Arm Assy.	4	4	
46	10201046A	Rubber Pad Assy.	4	4	
46A	10420138	Socket Bolt M6*16	12	12	
46B	10209134	Rubber Pad	4	4	
46C	11680030C	Support Frame	4	4	
47	10209034	Lock Washer φ8	15	15	
48	10209039	Washer φ10	27	27	
49	10209059	Anchor Bolts 3/4*5-1/2	12	12	
50	10206500B	Parts Box	1	0	
	10206501B		0	1	
51	10201002	Hex Bolt M8*16	9	9	
52	10206025A	Form Cushion	1	1	
53	1102072001A-01	Control Bar φ22*2400	1	1	
54	1103072003A-01	Control Bar Fixing bracket	2	2	
55	10206017	Hex Bolt M10*20	4	4	
56	1002022001	Limit Switch CZ-7121	1	1	
57	10420164	Cup Head Bolt M4*30	2	2	
58	110207007	Connecting Bush φ14*2*20	1	1	
59	10201122	Hex Bolt M8*35	1	1	
60	10620095	Hex Nut M4	2	2	
62	11206195-01	Top Beam A	1	1	
63	11206196-01	Top Beam B	1	1	
64	107820002	Socket Bolt	1	1	
65	81513001	Power unit 220V/50Hz/1 Phase	1/1	1/1	
	81513002	Power unit 380V/50Hz/3 Phase			
66	11206021	Pin for pulley	2	2	
67	11206022	Top pulley tube	2	2	
68	10206024	Hex Bolt M12*25	14	14	
69	11217024	Hose Support	2	2	
69A	1061K074	Protective Ring	2	2	
70	11203752	Protective Cover L=1140	2	0	
	11203756	Protective Cover L=1750	0	2	
70A	10206110	Cup head bolt M6*35	4	4	
71	11206084	Protective Cover L=200	2	2	
72	11206083	Protective Cover L=385	2	2	
73	10217008	Spring φ2.5*145°	1	1	
73A	10217030	Spring φ2.0*120°	2	2	
74	11217009	Safe Device	2	2	

Item	Part#	Description	Qty.		Note
			209C	209C	
75	10217010	Hex Bolt M6*40	1	1	
76	11217029	Pulley bracket	1	1	
76A	11217031	Cam Lock	1	1	
76B	10217032	Connect pin for cable	1	1	
76C	10217033	Self locking nut	1	1	
77	10203778	Protective cover L=1545	2	2	
77A	10206079	Cup Head bolt M6*40	14	14	
78	11206203	Offside column	1	1	
79	11209051B	Stackable adaptor (1.5")	4	4	
80	11209052B	Stackable adaptor (2.5")	4	4	
81	11209053B	Stackable adaptor (5")	4	4	
82	10217066	Hex Bolt M6*15	10	10	
83	10217011	Hex Nut M6	9	9	
84	10420045	Washer φ6	26	26	
85	10206064A	Cable L=10048mm	2	0	
	10206064B	Cable L=11268mm	0	2	
86	10206132-01	Oil Hose L=4470mm	1	0	
	10206133-01	Oil Hose L=5080mm	0	1	
87	10209060	90° fitting	1	1	
87A	10211016	T Fitting	1	1	
88	10209064	Straight fitting	2	2	
89	10206062	Straight fitting	2	2	
90	10233009	Straight fitting	2	2	
91	10206130-01	Oil Hose L=5350mm	2	0	
	10206131-01	Oil Hose L=5960mm	0	2	
92	10206200	Safety Cable L=7750mm	1	0	
	10206065A	Safety Cable L=8970mm	0	1	
93	10209066	Hex Nut M16	8	8	
94	10201090	Shim (1mm)	10	10	
	10620065	Shim (2mm)	10	10	
95	10209152	Tie 3*150mm	4	4	
96	10209149	Lock washer	18	18	
97	1102075001	Cable Limit Board	4	4	

1. Lifting arm (10203156):

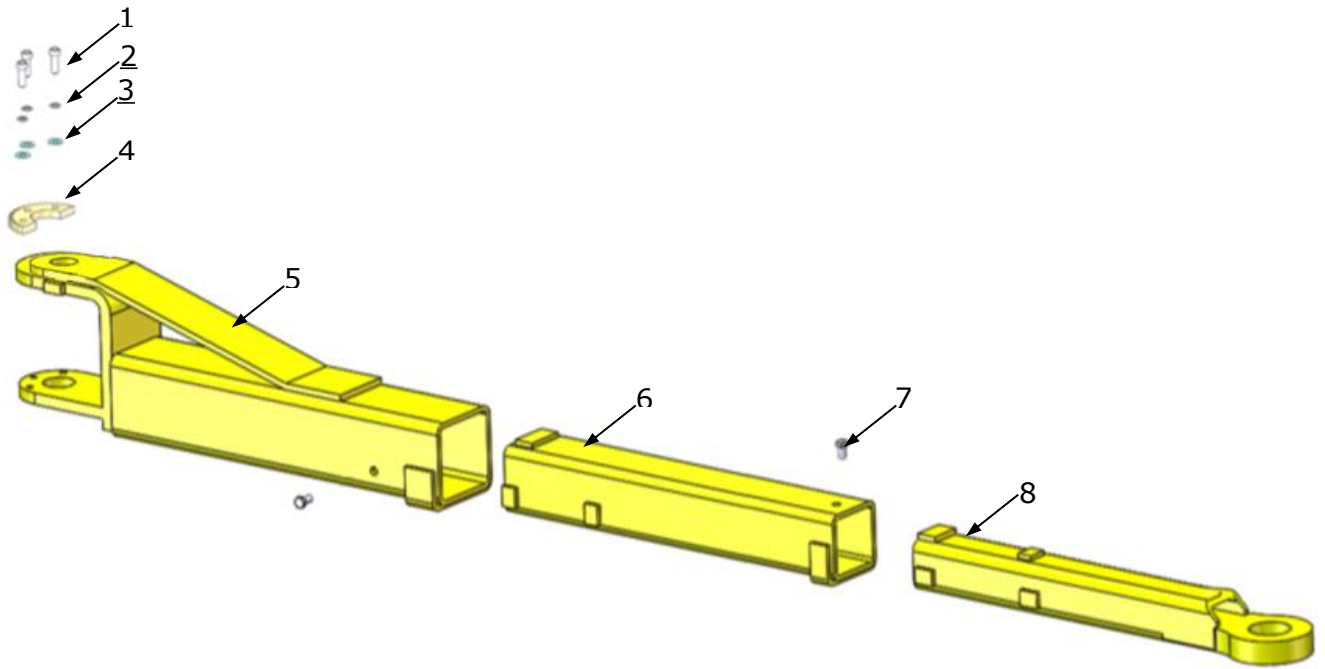

Fig. 44

Item	Parts#	Description	Qty.
1	10206048	Socket Bolt M10*30	12
2	10209039	Lock washer φ10	12
3	10209022	Washer φ10	12
4	11206049	Moon Gear	4
5	11203146	Outer arm	4
6	11203147	Middle arm	4
7	10201149	Cup Head bolt M8*12	8
8	11201049A	Inner Arm	4

2. Cylinders (10217056)

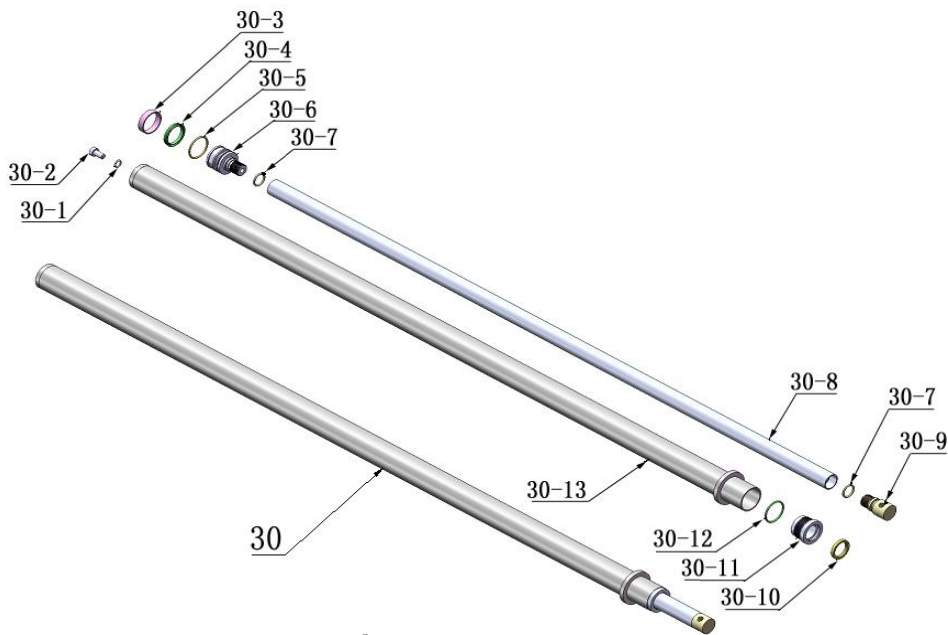

Fig. 45

Item	Parts#	Description	Qty.
30-1	10209069	O-Ring	2
30-2	10209070	Bleeding Plug	2
30-3	10209071	Support Ring	2
30-4	10209072	Y-Ring	2
30-5	10209073	O-Ring	2
30-6	11209074	Piston	2
30-7	11209075	O-Ring	2
30-8	11217076	Piston Rod	2
30-9	11209077	Piston Rod Fitting	2
30-10	10209078	Dust Ring	2
30-11	11209079	Head Cap	2
30-12	10209080	O-Ring	2
30-13	11209081A	Bore Weldment	2

3. Manual Power Unit (81513001/81513002) exploded view:

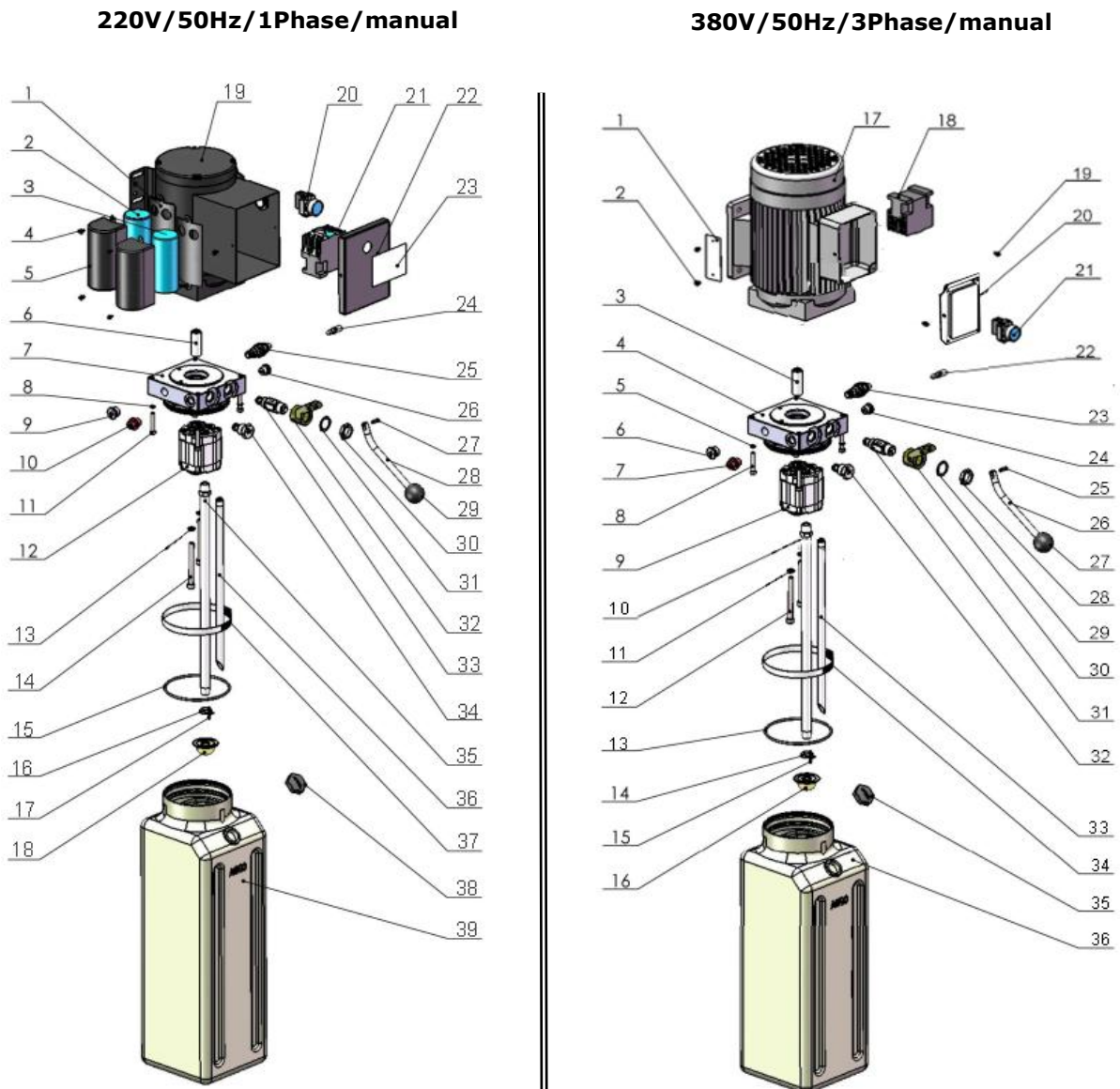

Fig. 46

Part list for 220V/50HZ/1phase

Item	Parts#	Description	Qty.
1	81400180	Rubber Pad	2
2	81400250	Start Capacitor	1
3	81400200	Running Capacitor	1
4	10420148	Cup head bolt	6
5	81400066	Capacitor Cover	2
6	81400363	Motor Connecting Shaft	1
7	80101013	Manifold Block	1
8	10209149	Spring Washer	4
9	81400276	Iron plug	1
10	81400259	Red Plastic plug	1
11	85090142	Socket Bolt	4
12	81400280	Gear Pump	1
13	10209034	Spring Washer	2

Item	Parts#	Description	Qty.
14	81400295	Socket Bolt	2
15	81400365	O Ring	1
16	10209152	Tie	1
17	85090167	Magnet	1
18	81400290	Filter	1
19	81400413	Motor	1
20	10420070	Push Button	1
21	41030055	Ac Contactor	1
22	81400528	Motor wire connecting cover	1
23	71111170	AMGO Name Plate	1
24	81400560	Throttle valve	1
25	81400266	Relief Valve	1
26	81400284	Socket Plug	1
27	10720118	Pin	1
28	81400451	Release Valve Handle	1
29	10209020	Plastic Ball	1
30	81400421	Reelase Valve Nut	1
31	81400422	Self Locking Nut	1
32	81400449	Vavle Seat (Short)	1
33	81400567	Release Vavle	1
34	81400566	Check Valve	1
35	81400288	Oil suction hose	1
36	81400289	Oil return hose	1
37	81400364	Clamp	1
38	81400263	Oil tank cover	1
39	81400275	Oil tank	1

Part list for 380V/50HZ/3phase

Item	Parts#	Description	Qty.
1	71150055	AMGO Name plate	1
2	81400300	Cuphead Bolt	2
3	81400363	Motor Connecting Shaft	1
4	81400362	Manifold Block	1
5	10209149	Spring Washer	4
6	81400276	Iron Plug	1
7	81400259	Red Plastic Plug	1
8	85090142	Socket Bolt	4
9	81400292	Gear Pump	1
10	81400288	Oil suction hose	1
11	10209034	Spring Wahser	2
12	81400295	Socket Bolt	2
13	81400365	O Ring	1
14	10209152	Tie	1
15	85090167	Magnet	1
16	81400290	Filter	1
17	81400439	Motor	1
18	81400348	AC Contactor	1
19	10420148	Cup Head Bold	2

Item	Parts#	Description	Qty.
20	81400481	Terminal Box For Motor	1
21	10420070	Push Button	1
22	81400560	Throttle valve	1
23	81400266	Relief Valve	1
24	81400284	Plug	1
25	81400452	Pin	1
26	81400451	Release Valve Handle	1
27	10209020	Plastic Ball	1
28	81400421	Release Valve Nut	1
29	81400422	Self Locked washser	1
30	81400449	Valve Seat	1
31	81400567	Release Valve	1
32	81400566	Check Valve	1
33	81400289	Oil Return Hose	1
34	81400364	clamp	1
35	81400263	Oil tank cover	1
36	81400275	Oil tank	1

4. Illustration of hydraulic valve for hydraulic power unit

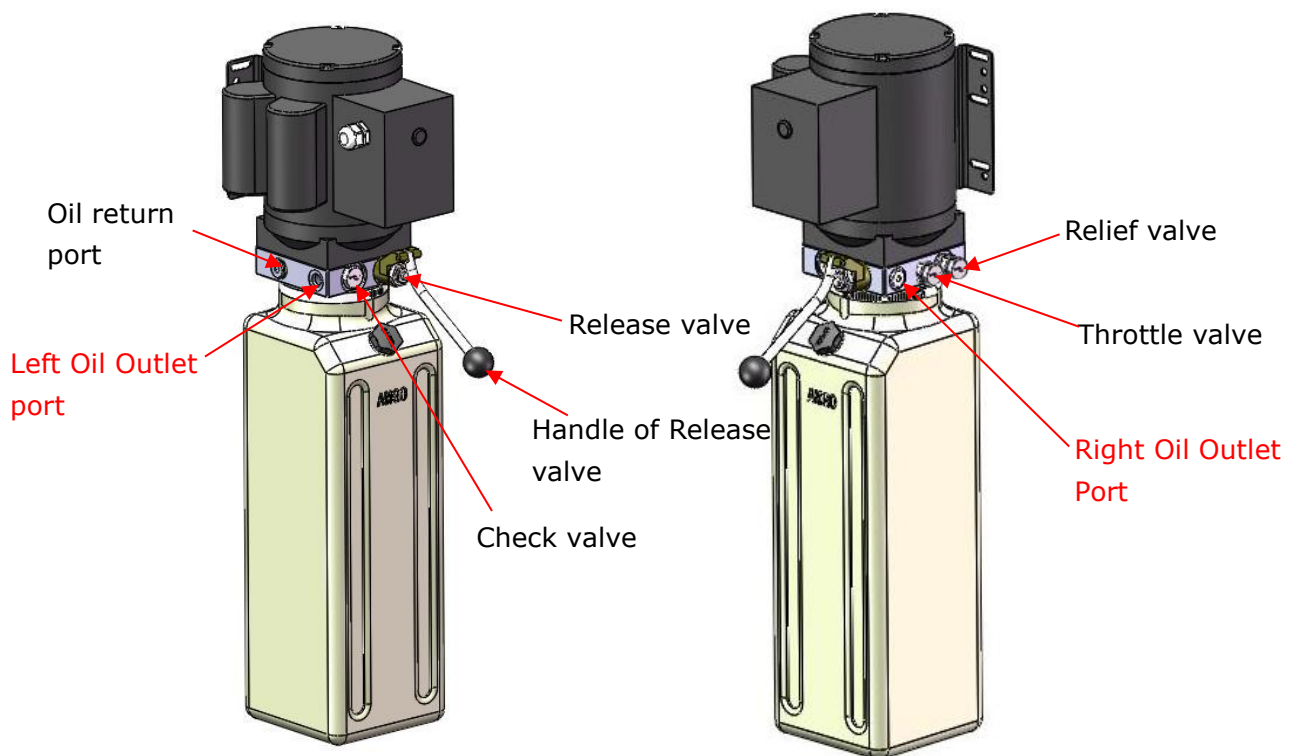

Fig. 47

V. TEST RUN

1. Adjustment of synchronous cable (See Fig. 48)

Use wrench to hold the cable fitting, meanwhile using ratchet spanner to tighten the cable nut until the two cables are in the same tension.

If the two vehicle carriages do not Synchronized when lifting and lowering, please screw and tighten the cable nut on the lower side carriage.

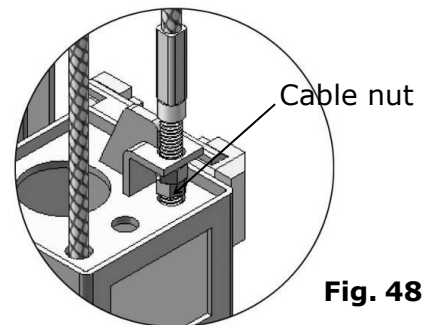

Fig. 48

2. Adjust safety cable

Rise the vehicle carriages and lock them at the same height, strain the safety cable and then release a little, and then tighten the safety cable nuts. Make sure the safety device can always lock the carriages properly.

At last, install the plastic cover of the safety device.

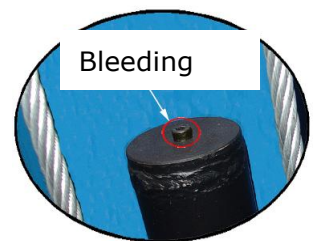

Fig. 49

2. Bleeding air from oil cylinder

This hydraulic system is designed with a bleeding plug, located at the top of the cylinder, Raise the carriages to about 1 meter height

and loose the bleeding plug, the air would be discharged automatically, then tighten The plug after bleeding air, the lift would work stably and smoothly, otherwise, repeat bleeding air.

4. Adjust the lowering speed

You can adjust the lowering speed of the lift if needing: screw the throttle valve clockwise to decrease the lowering speed, or counterclockwise to increase the lowering speed.

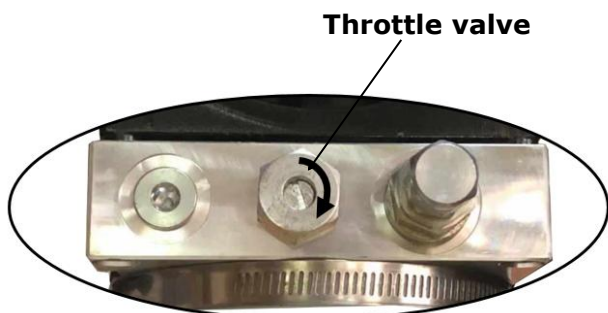

Adjust clockwise, decrease lowering speed

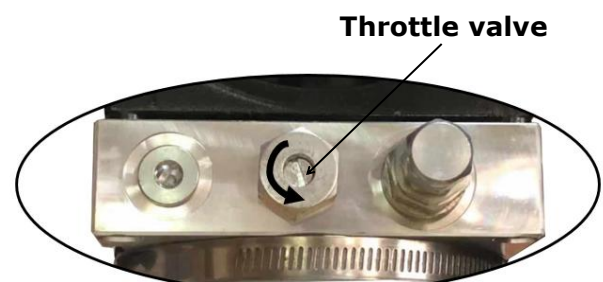

Counterclockwise, increase lowering speed

Fig. 50

5. Test with load

After finishing the above adjustment, perform a test run of the lift with a load. Run the lift in low position for the first few cycles, make sure the lift can rise and lower synchronously, the Safety Device can lock and release synchronously. And then test run the lift to the top completely. If there is anything improper, repeat the above adjustments until correct.

NOTE: It may be vibrated during the first lifting cycles, please lifting it with load for several times, the air would be bled and the vibration would be disappeared automatically.

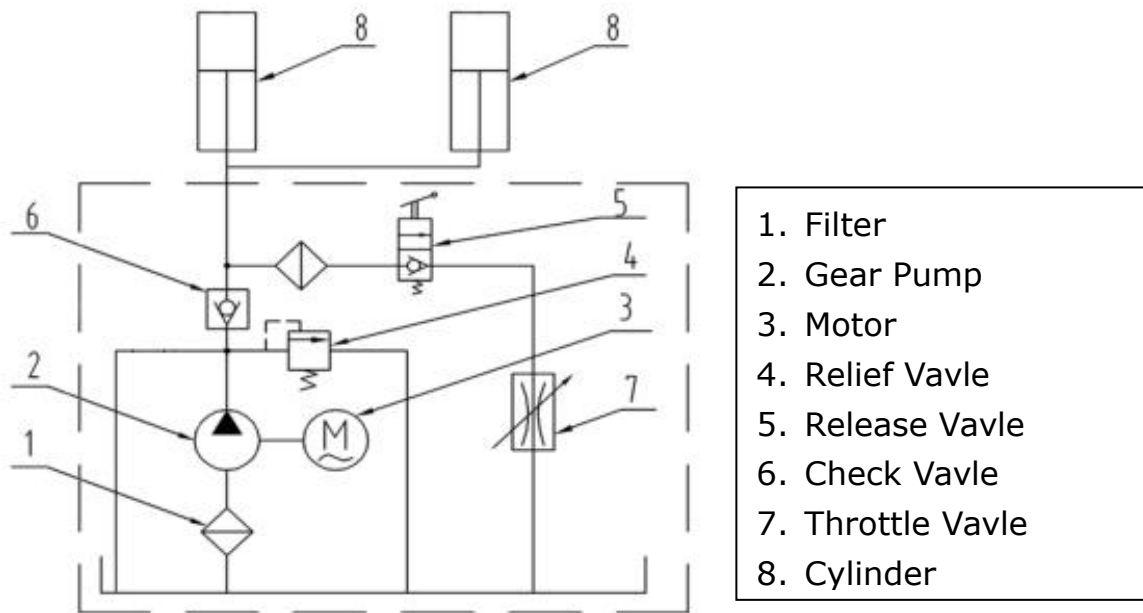

Fig. 51

VI. OPERATION INSTRUCTIONS

Please read the safety tips vehicle carefully before operating the lift

To lift vehicle

1. Keep clean of site near the lift;
2. Position lift arms to the lowest position;
3. To shorten lift arms;
4. Open lift arms;
5. Position vehicle between columns;
6. Move arms to the vehicle's lifting point;

Note: The four lift arms must at the same time contact the vehicle's lifting point where manufacturers recommended

7. Push the button of the power unit to lift until the lift pads contact underside of vehicle totally. Recheck to make sure vehicle is safe on the lift;
8. Continue to raise the lift slowly to the desired working height, ensuring the vehicle is balance on the lift;

9. Push lowering handle of power unit to lower lift onto the nearest safety lock. The vehicle is ready to repair.

To lower vehicle

1. Be sure clear of around and under the lift, only leaving operator in lift area;
2. Push button "UP" to raise the vehicle slightly, and then release the safety device, lower vehicle by pushing lowering handle.
3. Open the arms and position them to the shortest length;
4. Drive the vehicle away

VII.MAINTENANCE SCHEDULE

Monthly:

1. Re-torque the anchor bolts to 150 Nm;
2. Check all connectors, bolts and pins to insure proper mounting;
3. Lubricate cable with lubricant;
4. Make a visual inspection of all hydraulic hoses/lines for possible wear or leakage;
5. Check Safety device and make sure proper condition;
6. Lubricate all Rollers and Pins with 90wt. Gear oil or equivalent;

Note: All anchor bolts should take full torque. If any of the bolts does not function for any reason, DO NOT use the lift until the bolt has been replaced.

Every six months:

1. Make a visual inspection of all moving parts for possible wear, interference or damage.
2. Check and adjust as necessary, equalizer tension of the cables to insure level lifting.
3. Check columns for plumbness.
4. Check Rubber Pads and replace if necessary.
5. Check Safety device and make sure proper condition.

Oil cylinder maintenance:

In order to extend the service life of the oil cylinder, please operate according to the following requirements.

1. Recommend to use N46 anti-wear hydraulic oil.
2. The hydraulic oil of the lifts should be replaced regularly during using. Replace the hydraulic oil 3 months after the first installation, Replace the hydraulic oil once a year afterwards.
3. Make at least one full trip raising and lowering per day. For exhausting the air from the system, which could effectively avoid the corrosion of the cylinder and damage to the seals caused by presence of air or water in the system.
4. Protect the outer surface of the oil cylinder's piston rod from bumping and

scratching, and timely clean up the debris on the oil cylinder dust-ring and the piston rod.

VIII. TROUBLE SHOOTING

TROUBLE	CAUSE	REMEDY
Motor does not run	<ol style="list-style-type: none"> 1. Button does not work 2. Wiring connections are not in good condition 3. Motor burned out 4. Height limit switch is damaged 5. AC contactor burned out 	<ol style="list-style-type: none"> 1. Replace button 2. Repair all wiring connections 3. Repair or replace motor 4. Replace the limit switch 5. Replace AC contactor
Motor runs but the lift is not raised	<ol style="list-style-type: none"> 1. Motor runs in reverse rotation 2. Gear pump out of operation 3. Release valve in damage 4. Relief valve or check valve in damage 5. Low oil level 	<ol style="list-style-type: none"> 1. Reverse two power wire 2. Repair or replace 3. Repair or replace 4. Repair or replace 5. Fill tank
Lift does not stay up	<ol style="list-style-type: none"> 1. Release valve out of work 2. Relief valve or check valve leakage 3. Cylinder or Fittings leaks 	Repair or replace
Lift raises slowly	<ol style="list-style-type: none"> 1. Oil line is jammed 2. Motor running on low voltage 3. Oil mixed with air 4. Gear Pump leaks 5. Overload lifting 	<ol style="list-style-type: none"> 1. Clean the oil line 2. Check Electrical System 3. Fill tank 4. Replace Pump 5. Check load
Lift cannot lower	<ol style="list-style-type: none"> 1. Safety device are locking 2. Release valve in damage 3. Safety cable broken 4. Oil system is jammed 	<ol style="list-style-type: none"> 1. Release the safeties 2. Repair or replace 3. Replace 4. Clean the oil system

IX. Lift disposal.

When the car lift cannot meet the requirements for normal use and needs to be disposed, it should follow local laws and regulations.



Manual No.: 72220612
Revise Date: 2022/13